



# PROCEEDING

#3rd

# ISRITI 2020

Yogyakarta - Indonesia  
10 December 2020

**ARTIFICIAL INTELLIGENCE  
for SOCIAL INTERACTIONS**

[isriti.akakom.ac.id](http://isriti.akakom.ac.id)



STMIK AKAKOM  
YOGYAKARTA



IEEE  
INDONESIA SECTION

## THE COMMITTEE

### STEERING COMMITTEE

Chuan-Ming Liu (National Taipei University of Technology, Taiwan)  
Totok Suprawoto (STMIK AKAKOM Yogyakarta, Indonesia)  
Widyastuti Andriyani (STMIK AKAKOM Yogyakarta, Indonesia)

### ORGANIZING COMMITTEE

*General Chair*  
Bambang Purnomosidi Dwi Putranto (STMIK AKAKOM Yogyakarta, Indonesia)  
*Deputy of General Chair*  
Maria Mediatrix (STMIK AKAKOM Yogyakarta, Indonesia)  
*Secretary*  
Edy Prayitno (STMIK AKAKOM Yogyakarta, Indonesia)  
*Treasury*  
Sumiyatun Sumiyatun (STMIK AKAKOM Yogyakarta, Indonesia)  
*Publication Chair*  
Setyawan Widarto (Universiti Selangor, Malaysia)  
*Chair of TPC*  
Domy Kristomo (STMIK AKAKOM Yogyakarta, Indonesia)

### TECHNICAL COMMITTEE

Muhammad Agung Nugroho (STMIK AKAKOM Yogyakarta, Indonesia)  
Luthfan Hadi Pramono (STMIK AKAKOM Yogyakarta, Indonesia)  
Siska Lidya Revianti (STMIK AKAKOM Yogyakarta, Indonesia)  
Ariesta Damayanti (STMIK AKAKOM Yogyakarta, Indonesia)  
Robby Cokro Buwono (STMIK AKAKOM Yogyakarta, Indonesia)  
Agung Budi Prasetyo (STMIK AKAKOM Yogyakarta, Indonesia)  
Muhammad Guntara (STMIK AKAKOM Yogyakarta, Indonesia)

## AUTHOR INDEX

Author	Session	Start page	Title
<b>A    A B C D E F G H I J K L M N O P Q R S T U W X Y Z</b>			
Abadi, Imam	3E.3	716	<i>Energy Management Efficiency and Stability Using Passive Filter in Standalone Photovoltaic Sudden Cloud Condition</i>
Abdillah, Rahmad	3A.1	621	<i>Facial Expression Recognition and Face Recognition Using a Convolutional Neural Network</i>
Abdul-Jabbar, Jassim	3B.4	655	<i>A Robust Iris Segmentation Algorithm Based on Pupil Region for Visible Wavelength Environments</i>
Adi, Sumarni	1C.2	94	<i>The Best Parameter Tuning on RNN Layers for Indonesian Text Classification</i>
Aditya, Christian Sri Kusuma	1D.5	152	<i>Comparative Analysis of DDoS Detection Techniques Based on Machine Learning in OpenFlow Network</i>
Aditya, Trias	2G.5	604	<i>Comparison of the Latest DTM with DEM Pleiades in Monitoring the Dynamic Peatland</i>
Adrian, Ronald	1E.5	198	<i>Roadside Unit Power Saving using Vehicle Detection System in Vehicular Ad-hoc Network</i>
Afdhal, Afdhal	2E.3	509	<i>Convolutional Network and Moving Object Analysis for Vehicle Detection in Highway Surveillance Videos</i>
Affandi, Achmad	1G.1	267	<i>A Combination of Defected Ground Structure and Line Resonator for Mutual Coupling Reduction</i>
Agustina, Dina	1B.2	48	<i>Prediction of forest fire occurrence in peatlands using machine learning approaches</i>
Akbar, Renal	1D.6	158	<i>Performance Analysis FSR and DSR Routing Protocol in VANET with V2V and V2I Models</i>
Akhsanta, Muhammad	2E.6	525	<i>Text-Independent Speaker Identification Using PCA-SVM Model</i>
Al Aufa, Badra	2F.6	562	<i>Measuring Instagram Activity and Engagement Rate of Hospital: A Comparison Before and During COVID-19 Pandemic</i>
Al Maki, Wikky	1B.8	73	<i>Hybrid Method for Flower Classification in High Intra-class Variation</i>
Alam, Sahirul	1E.5	198	<i>Roadside Unit Power Saving using Vehicle Detection System in Vehicular Ad-hoc Network</i>

Alamsyah, Rangga	3B.2	646	<i>Speech Gender Classification Using Bidirectional Long Short Term Memory</i>
Alfi, Farah	1F.2	227	<i>Quality Assessment of Digital Terrestrial Television Broadcast in Surabaya</i>
Ali, Tarig Ahmed El Khider	1B.7	68	<i>Risk Prediction of Major Depressive Disorder using Artificial Neural Network</i>
Alief, Fahdiaz	1F.3	233	<i>Android Forensic Tools Analysis for Unsend Chat on Social Media</i>
Amalia, Yasmin	2D.2	457	<i>Benchmarking Explicit Rating Prediction Algorithms for Cosmetic Products</i>
Amanaf, Muntaqo	1G.3	278	<i>5G New Radio (NR) Network Planning at Frequency 2,6 GHz in The Gold Triangle Area of Jakarta</i>
Ambarwari, Agus	2B.7	389	<i>Design and prototype development of internet of things for greenhouse monitoring system</i>
Andriyani, Widyastuti	2B.6	383	<i>A Comparative Study of Java and Kotlin for Android Mobile Application Development</i>
	1B.2	48	<i>Prediction of forest fire occurrence in peatlands using machine learning approaches</i>
Anggraeni, Martianda	1F.2	227	<i>Quality Assessment of Digital Terrestrial Television Broadcast in Surabaya</i>
Annisa, Fadhilah Qalbi	1B.8	79	<i>Personality Dimensions Classification with EEG Analysis using Support Vector Machine</i>
Antonius, Suyanto	2E.7	529	<i>Center of Gravity Method for Finding Center of Laser Beam Projection on Landslide Measurement</i>
Anugraha, Tides	1D.3	140	<i>Experimental Security Analysis for Fake eNodeB Attack on LTE Network</i>
Anwar, Muchamad Taufiq	1C.1	83	<i>Performance Comparison of Data Mining Techniques for Rain Prediction Models in Indonesia</i>
Archi, Muhammad	1E.2	182	<i>Initial Access in 5G mmWave Communication using Hybrid Genetic Algorithm and Particle Swarm Optimization</i>
Ardiansyah, Agus	2B.5	377	<i>Prototype Design of IoT (Internet of Things)-based Load Monitoring System</i>
Arfian, Nur	2B.1	354	<i>The User Experience effect of Applying Floating Action Button (FAB) into Augmented Reality Anatomy Cranium Media Learning Prototype</i>
Ariananda, Dyonisius	1F.5	245	<i>Single Snapshot-Spatial Compressive Beamforming for Azimuth Estimation and Backscatter Reconstruction</i>



Aripriharta, A.	2B.4	371	<i>Development of The Personnel Monitoring System Using Mobile Application and Real-Time Database During the COVID19 Pandemic</i>
Arisanty, Deasy	1B.2	48	<i>Prediction of forest fire occurrence in peatlands using machine learning approaches</i>
Arisya, Khairunnisa	1D.8	170	<i>Measurement of Information Security Awareness Level: A Case Study of Online Transportation Users</i>
Armin, Farid	1G.4	284	<i>Modification of 2.2 GHz S-Band Rectangular Patch Microstrip Antenna using Truncated Corner Method for Satellite Applications</i>
	1G.5	289	<i>Design of Optimal Satellite Constellation for Indonesian Regional Navigation System based on GEO and GSO Satellites</i>
Arwoko, Heru	3D.1	682	<i>Fruits Classification from Image using MPEG-7 Visual Descriptors and Extreme Learning Machine</i>
Asfihani, Tahiyatul	1G.8	306	<i>Ship Heading Control Using Nonlinear Model Predictive Control</i>
Asriningtias, Salnan	1A.2	7	<i>Blackbox Testing Model Boundary Value of Mapping Taxonomy Applications and Data Analysis of Art and Artworks</i>
Astuti, Eha Renwi	3C.2	661	<i>The Use of Pre and Post Processing to Enhance Mandible Segmentation using Active Contours on Dental Panoramic Radiography Images</i>
Astuti, Yenni	3B.1	642	<i>Comparison of Feature Extraction for Speaker Identification System</i>
Asyrofi, Rakha	2A.5	332	<i>Extraction Dependency Based on Evolutionary Requirement Using Natural Language Processing</i>
<b>B A B C D E F G H I J K L M N O P Q R S T U W X Y Z</b>			
Basari, Basari	2B.3	365	<i>Proximity-based COVID-19 Contact Tracing System Devices for Locally Problems Solution</i>
Bejo, Agus	3B.1	642	<i>Comparison of Feature Extraction for Speaker Identification System</i>
	1B.3	52	<i>Speaker Recognition Using Mel Frequency Cepstral Coefficient and Self-Organising Fuzzy Logic</i>
Belangour, Abdessamad	3A.4	638	<i>A Kubernetes Algorithm for scaling Virtual Objects</i>
Borman, Rohmat	2E.5	520	<i>Indonesian Traffic Sign Recognition For Advanced Driver Assistent (ADAS) Using YOLOv4</i>

Budi Setiawan, Fajar	1E.8	215	<i>Performance Enhancement in Macro-Femto Network Using a Modified Discrete Moth-flame Optimization Algorithm</i>
Budiman, Edy	2D.7	482	<i>Dayak Onion (<i>Eleutherine palmifolia</i> (L) Merr) as An Alternative Treatment in Early Detection of Dental Caries using Certainty Factor</i>
Bustamam, Alhadi	1A.6	26	<i>The Multimodal Transfer Learning for Diagnosing COVID-19 Pneumonia from Chest CT-Scan and X-Ray Images</i>
<b>C      A B C D E F G H I J K L M N O P Q R S T U W X Y Z</b>			
Cahyani, Denis	1B.4	56	<i>Indonesian Parsing using Probabilistic Context-Free Grammar (PCFG) and Viterbi-Cocke Younger Kasami (Viterbi-CYK)</i>
Chotimah, Khusnul	1G.8	306	<i>Ship Heading Control Using Nonlinear Model Predictive Control</i>
<b>D      A B C D E F G H I J K L M N O P Q R S T U W X Y Z</b>			
Daelami, Ahmad	2F.5	551	<i>Development of Temperature and Humidity Control System in Internet-of-Things based Oyster Mushroom Cultivation</i>
Darari, Fariz	2D.2	457	<i>Benchmarking Explicit Rating Prediction Algorithms for Cosmetic Products</i>
Delfianti, Rezi	3E.3	716	<i>Energy Management Efficiency and Stability Using Passive Filter in Standalone Photovoltaic Sudden Cloud Condition</i>
Dewantara, Mahardira	2C.1	400	<i>Minimization of Power Losses through Optimal Placement and Sizing from Solar Power and Battery Energy Storage System in Distribution System</i>
Dirgantoro, Burhanuddin	2E.4	514	<i>Speaker Recognition For Digital Forensic Audio Analysis Using Support Vector Machine</i>
Djawas, Faizah	2F.6	562	<i>Measuring Instagram Activity and Engagement Rate of Hospital: A Comparison Before and During COVID-19 Pandemic</i>
Dwijayanti, Suci	3A.1	621	<i>Facial Expression Recognition and Face Recognition Using a Convolutional Neural Network</i>
Dwiputra, Richard	1E.6	203	<i>Network Attack Detection System Using Filter-based Feature Selection and SVM</i>
<b>E      A B C D E F G H I J K L M N O P Q R S T U W X Y Z</b>			
Eka Sari, Wahyuni	1B.1	42	<i>Papaya Disease Detection Using Fuzzy Naïve Bayes Classifier</i>

Ekana, Raki	1A.5	21	<i>PSO-Learned Artificial Neural Networks for Activity Recognition</i>
Eko Sulisty, Meiyanto	2C.6	428	<i>Design and Development of Bit Error Measurement using FPGA for Visible Light Communication</i>
El Khalyly, Badr	3A.4	638	<i>A Kubernetes Algorithm for scaling Virtual Objects</i>
Elsa, Corry	2G.1	577	<i>Case Study: AppDynamics Application as Business Intelligence to Support Digital Business Operations at PT PGD</i>
Emanuel, Andi Wahyu Rahardjo	1C.3	100	<i>Influence Distribution Training Data on Performance Supervised Machine Learning Algorithms</i>
Engel, Ventje	1E.6	203	<i>Network Attack Detection System Using Filter-based Feature Selection and SVM</i>
<b>F A B C D E F G H I J K L M N O P Q R S T U W X Y Z</b>			
Fachrie, Muhammad	2G.1	583	<i>Guided Genetic Algorithm to Solve University Course Timetabling with Dynamic Time Slot</i>
Fadhilah, Amanda	1D.8	170	<i>Measurement of Information Security Awareness Level: A Case Study of Online Transportation Users</i>
Fahmi, Fahmi	2B.4	371	<i>Development of The Personnel Monitoring System Using Mobile Application and Real-Time Database During the COVID19 Pandemic</i>
Fahrudin, Tresna	2A.7	344	<i>Indonesian Stock Price Prediction including Covid19 Era Using Decision Tree Regression</i>
Fanani, M.	1C.7	117	<i>Implementation of Maximum Power Point Tracking on PV System using Artificial Bee Colony Algorithm</i>
Faraby, Muhira	2C.4	418	<i>The Single Tuned Filter Planning to Mitigate Harmonic Pollution in Radial Distribution Network Using Particle Swarm Optimization</i>
Fardan, Fardan	1D.3	140	<i>Experimental Security Analysis for Fake eNodeB Attack on LTE Network</i>
Farrell, Mochammad	2E.3	505	<i>Combined Firefly Algorithm-Random Forest to Classify Autistic Spectrum Disorders</i>
Fatichah, Chastine	3C.2	661	<i>The Use of Pre and Post Processing to Enhance Mandible Segmentation using Active Contours on Dental Panoramic Radiography Images</i>
Ferdiansyah, Indra	1C.7	117	<i>Implementation of Maximum Power Point Tracking on PV System using Artificial Bee Colony Algorithm</i>

	2C.3	412	<i>Design and Implementation of SVPWM Inverter to Reduce Total Harmonic Distortion (THD) on Three Phase Induction Motor Speed Regulation Using Constant V/F</i>
	2C.2	406	<i>Three Phase Induction Motor Dynamic Speed Regulation Using IP Controller</i>
Firdaus, Diash	1D.7	164	<i>DDoS Attack Detection in Software Defined Network using Ensemble K-means++ and Random Forest</i>
Firdaus, Diaz	2D.6	476	<i>Topic-Based Tweet Clustering for Public Figures Using Ant Clustering</i>
Fitria, Irma	1G.8	306	<i>Ship Heading Control Using Nonlinear Model Predictive Control</i>
Fitriati, Andi	2C.4	418	<i>The Single Tuned Filter Planning to Mitigate Harmonic Pollution in Radial Distribution Network Using Particle Swarm Optimization</i>
Frannita, Eka	2E.2	499	<i>Supervised Deep Learning for Thyroid Nodules Classification Based on Margin Characteristic</i>
<b>G      A B C D E F G H I J K L M N O P Q R S T U W X Y Z</b>			
Ginting, Ishak	1D.3	140	<i>Experimental Security Analysis for Fake eNodeB Attack on LTE Network</i>
Gitakarma, Made Santo	1F.1	221	<i>Designing Wireless Sensor Network Routing on Agriculture Area Using The LEACH Protocol</i>
Gumilar, Langlang	3E.2	711	<i>Variations in the Placement of DFIG in the Power System to Changes of Short Circuit Current</i>
Gunawan, Dadang	1E.2	182	<i>Initial Access in 5G mmWave Communication using Hybrid Genetic Algorithm and Particle Swarm Optimization</i>
Gupta, Anju	2C.9	445	<i>Robust Control Design Procedure and Simulation of PRES Controller having Phase-Locked Loop(PLL) control technique in Grid-Tied Converter</i>
<b>H      A B C D E F G H I J K L M N O P Q R S T U W X Y Z</b>			
Hadikurniawati, Wiwien	1C.1	83	<i>Performance Comparison of Data Mining Techniques for Rain Prediction Models in Indonesia</i>
Halim, Arwin	2A.4	326	<i>Optimization of SV-kNNC using Silhouette Coefficient and LMKNN for Stock Price Prediction</i>
Hamed, Fatima	1B.7	68	<i>Risk Prediction of Major Depressive Disorder using Artificial Neural Network</i>

Hamka Ibrahim, Muhammad	2C.6	428	<i>Design and Development of Bit Error Measurement using FPGA for Visible Light Communication</i>
Hanifa, Annisa	2C.6	428	<i>Design and Development of Bit Error Measurement using FPGA for Visible Light Communication</i>
Harintaka, Harintaka	2G.5	604	<i>Comparison of the Latest DTM with DEM Pleiades in Monitoring the Dynamic Peatland</i>
Hartanto, Rudy	2B.1	354	<i>The User Experience effect of Applying Floating Action Button (FAB) into Augmented Reality Anatomy Cranium Media Learning Prototype</i>
	2G.3	593	<i>Multi-Point Travel Destination Recommendation System In Yogyakarta Using Hybrid Location Based Service-Floyd Warshall Method</i>
Hasibuan, Siti	1B.3	52	<i>Speaker Recognition Using Mel Frequency Cepstral Coefficient and Self-Organising Fuzzy Logic</i>
Hasim, Sitronella	1F.8	262	<i>Performance Evaluation of Cell-Edge Femtocell Densely Deployed in OFDMA-Based Macrocellular Network</i>
Hastuti, Puji	2G.4	599	<i>Application For Detection Of Pedestrian Position On Zebra Cross</i>
Hermawan, Tofan	1F.3	233	<i>Android Forensic Tools Analysis for Unsend Chat on Social Media</i>
Hermawati, Hermawati	3A.1	621	<i>Facial Expression Recognition and Face Recognition Using a Convolutional Neural Network</i>
Herumurti, Darlis	3C.2	661	<i>The Use of Pre and Post Processing to Enhance Mandible Segmentation using Active Contours on Dental Panoramic Radiography Images</i>
Hery, Hery	1C.1	89	<i>Website Design for Locating Tuna Fishing Spot Using Naïve Bayes and SVM Based on VMS Data on Indonesian Sea</i>
Hidayat, Firhat	1E.6	203	<i>Network Attack Detection System Using Filter-based Feature Selection and SVM</i>
Hidayat, Risanuri	3B.1	642	<i>Comparison of Feature Extraction for Speaker Identification System</i>
	1F.5	245	<i>Single Snapshot-Spatial Compressive Beamforming for Azimuth Estimation and Backscatter Reconstruction</i>
	1B.3	52	<i>Speaker Recognition Using Mel Frequency Cepstral Coefficient and Self-Organising Fuzzy Logic</i>
Hidayat, Taufik	2G.7	615	<i>Validation of Information Technology Value Model for Petroleum Industry</i>

	2G.6	609	<i>Model Development of Information Technology Value for Downstream Petroleum Industry</i>
	2F.1	534	<i>Effect of Android and Social Media User Growth on the Financial Technology Lending Borrowers and its Financing</i>
Hikmah, Awaliyatul	1C.2	94	<i>The Best Parameter Tuning on RNN Layers for Indonesian Text Classification</i>
Hikmarika, Hera	3A.1	621	<i>Facial Expression Recognition and Face Recognition Using a Convolutional Neural Network</i>
Hikmaturokhman, Alfin	1G.3	278	<i>5G New Radio (NR) Network Planning at Frequency 2,6 GHz in The Gold Triangle Area of Jakarta</i>
	1G.2	272	<i>Techno-Economic 5G New Radio Planning at 26 GHz Frequency in Pulogadung Industrial Area</i>
Hilmizen, Naufal	1A.6	26	<i>The Multimodal Transfer Learning for Diagnosing COVID-19 Pneumonia from Chest CT-Scan and X-Ray Images</i>
Hindrayani, Kartika	2A.7	344	<i>Indonesian Stock Price Prediction including Covid19 Era Using Decision Tree Regression</i>
Husin, Zaenal	3A.1	621	<i>Facial Expression Recognition and Face Recognition Using a Convolutional Neural Network</i>
Hutami, Augustine	2E.2	499	<i>Supervised Deep Learning for Thyroid Nodules Classification Based on Margin Characteristic</i>
<b>I A B C D E F G H I J K L M N O P Q R S T U W X Y Z</b>			
Iftadi, Irwan	2C.6	428	<i>Design and Development of Bit Error Measurement using FPGA for Visible Light Communication</i>
Indriawati, Katherin	1G.6	295	<i>Particle Filter Based Speed Estimator for Speed Sensorless Control in Induction Motor</i>
	1G.7	301	<i>Disturbance Observer-Based Speed Estimator for Controlling Speed Sensorless Induction Motor</i>
Irawan, Arif	2B.8	394	<i>Smart Safe Prototype Based Internet of Things (IoT) with Face and Fingerprint Recognition</i>
Irnanan, Roni	2C.1	400	<i>Minimization of Power Losses through Optimal Placement and Sizing from Solar Power and Battery Energy Storage System in Distribution System</i>
Iskandar, Nur Muhamad	1G.1	267	<i>A Combination of Defected Ground Structure and Line Resonator for Mutual Coupling Reduction</i>
Isnandar, Suroso	2C.5	423	<i>Analysis of Performance Index in Transmission Expansion Planning of Sulawesi's Electricity System</i>

Istikmal, Istikmal	1D.3	140	<i>Experimental Security Analysis for Fake eNodeB Attack on LTE Network</i>
	1D.6	158	<i>Performance Analysis FSR and DSR Routing Protocol in VANET with V2V and V2I Models</i>
	2B.8	394	<i>Smart Safe Prototype Based Internet of Things (IoT) with Face and Fingerprint Recognition</i>
<b>J      A B C D E F G H I J K L M N O P Q R S T U W X Y Z</b>			
Jati Anggoro, Wisang	1E.7	209	<i>Development of Smart Energy Meter Based on LoRaWAN in Campus Area</i>
Jatmiko, Wisnu	2E.5	520	<i>Indonesian Traffic Sign Recognition For Advanced Driver Assistent (ADAS) Using YOLOv4</i>
Julzarika, Atriyon	2G.5	604	<i>Comparison of the Latest DTM with DEM Pleiades in Monitoring the Dynamic Peatland</i>
<b>K      A B C D E F G H I J K L M N O P Q R S T U W X Y Z</b>			
Kamirul, Kamirul	1G.4	284	<i>Modification of 2.2 GHz S-Band Rectangular Patch Microstrip Antenna using Truncated Corner Method for Satellite Applications</i>
	1G.5	289	<i>Design of Optimal Satellite Constellation for Indonesian Regional Navigation System based on GEO and GSO Satellites</i>
Karna, Nyoman	1D.3	140	<i>Experimental Security Analysis for Fake eNodeB Attack on LTE Network</i>
Karo, Ferdinanta	1G.3	278	<i>5G New Radio (NR) Network Planning at Frequency 2,6 GHz in The Gold Triangle Area of Jakarta</i>
Khairunnisa, Syifa	2D.5	471	<i>Removing Noise, Reducing dimension, and Weighting Distance to Enhance k-Nearest Neighbors for Diabetes Classification</i>
Komarudin, Udin	2F.5	551	<i>Development of Temperature and Humidity Control System in Internet-of-Things based Oyster Mushroom Cultivation</i>
Kouty, Shreyus	2C.8	439	<i>Multilayer Secure Hardware Network Stack using FPGA</i>
Krisnadi, Dion	1C.1	89	<i>Website Design for Locating Tuna Fishing Spot Using Naïve Bayes and SVM Based on VMS Data on Indonesian Sea</i>
Kristiani, Eveline	2G.1	577	<i>Case Study: AppDynamics Application as Business Intelligence to Support Digital Business Operations at PT PGD</i>



Kunang, Yesi	1D.4	146	<i>Improving Classification Attacks in IOT Intrusion Detection System using Bayesian Hyperparameter Optimization</i>
Kurniawati, Yulia Ery	1B.1	42	<i>Papaya Disease Detection Using Fuzzy Naïve Bayes Classifier</i>
Kusnandar, Kusnandar	2F.5	551	<i>Development of Temperature and Humidity Control System in Internet-of-Things based Oyster Mushroom Cultivation</i>
<b>L      A B C D E F G H I J K L M N O P Q R S T U W X Y Z</b>			
Lagunov, Alexey	3E.1	705	<i>Features of the Use of Solar Panels at Low Temperatures in the Arctic</i>
Lee, HoonJae	1E.3	187	<i>TwoChain: Leveraging Blockchain and Smart Contract for Two Factor Authentication</i>
Lee, Sang-Gon	1E.3	187	<i>TwoChain: Leveraging Blockchain and Smart Contract for Two Factor Authentication</i>
Lin, Haitao	1A.2	12	<i>Distributed Alternating Direction Multiplier Method Based on Optimized Topology and Nodes Selection Strategy</i>
Lubis, Ainul	2B.3	365	<i>Proximity-based COVID-19 Contact Tracing System Devices for Locally Problems Solution</i>
Lukas, Samuel	1C.1	89	<i>Website Design for Locating Tuna Fishing Spot Using Naïve Bayes and SVM Based on VMS Data on Indonesian Sea</i>
<b>M      A B C D E F G H I J K L M N O P Q R S T U W X Y Z</b>			
Mahamad, Abd Kadir	2B.4	371	<i>Development of The Personnel Monitoring System Using Mobile Application and Real-Time Database During the COVID19 Pandemic</i>
Mahardiko, Rahutomo	2G.7	615	<i>Validation of Information Technology Value Model for Petroleum Industry</i>
	2G.6	609	<i>Model Development of Information Technology Value for Downstream Petroleum Industry</i>
	2F.1	534	<i>Effect of Android and Social Media User Growth on the Financial Technology Lending Borrowers and its Financing</i>
Mahersatillah, Andi	3D.2	688	<i>Unstructured Road Detection and Steering Assist Based on HSV Color Space Segmentation for Autonomous Car</i>
Mahfiz, Syiti	2D.8	488	<i>Aspect-based Opinion Mining on Beauty Product Reviews</i>



Manik, Lindung	3A.2	627	<i>Stemming Javanese: Another Adaptation of the Nazief-Adriani Algorithm</i>
Mardhotillah, Rinda	2E.4	514	<i>Speaker Recognition For Digital Forensic Audio Analysis Using Support Vector Machine</i>
Masngut, Ibnu	2B.2	360	<i>Development and Implementation of Kalman Filter for IoT Sensors: Towards a Better Precision Agriculture</i>
Maulana, Eka	1E.7	209	<i>Development of Smart Energy Meter Based on LoRaWAN in Campus Area</i>
Mawaldi, Iqbal	1D.3	140	<i>Experimental Security Analysis for Fake eNodeB Attack on LTE Network</i>
Mootha, Siddartha	3E.4	721	<i>A Stacking Ensemble of Multi Layer Perceptrons to Predict Online Shoppers' Purchasing Intention</i>
Mubarok, Husein	2B.5	377	<i>Prototype Design of IoT (Internet of Things)-based Load Monitoring System</i>
Muchtar, Akhyar	2C.4	418	<i>The Single Tuned Filter Planning to Mitigate Harmonic Pollution in Radial Distribution Network Using Particle Swarm Optimization</i>
Muchtar, Kahlil	2E.3	509	<i>Convolutional Network and Moving Object Analysis for Vehicle Detection in Highway Surveillance Videos</i>
Muflikhah, Laili	1A.8	37	<i>Prediction of Liver Cancer Based on DNA Sequence Using Ensemble Method</i>
Muharram, Muh.	2D.4	467	<i>Firefly Algorithm-based Optimization of Base Transceiver Station Placement</i>
Mujahidin, Irfan	1A.2	7	<i>Blackbox Testing Model Boundary Value of Mapping Taxonomy Applications and Data Analysis of Art and Artworks</i>
Muladi, Muladi	2B.4	371	<i>Development of The Personnel Monitoring System Using Mobile Application and Real-Time Database During the COVID19 Pandemic</i>
Mulyanto, Agus	2E.5	520	<i>Indonesian Traffic Sign Recognition For Advanced Driver Assistent (ADAS) Using YOLOv4</i>
Munadi, Rendy	1D.7	164	<i>DDoS Attack Detection in Software Defined Network using Ensemble K-means++ and Random Forest</i>
Mungkasi, Sudi	2A.2	321	<i>Some Numerical and Analytical Solutions to an Enzyme-Substrate Reaction-Diffusion Problem</i>
Mursanto, Petrus	2E.5	520	<i>Indonesian Traffic Sign Recognition For Advanced Driver Assistent (ADAS) Using YOLOv4</i>

Murwantara, I Made	1C.1	89	<i>Website Design for Locating Tuna Fishing Spot Using Naïve Bayes and SVM Based on VMS Data on Indonesian Sea</i>
Mustika, I Wayan	1E.5	198	<i>Roadside Unit Power Saving using Vehicle Detection System in Vehicular Ad-hoc Network</i>
	1E.8	215	<i>Performance Enhancement in Macro-Femto Network Using a Modified Discrete Moth-flame Optimization Algorithm</i>
	1E.7	209	<i>Development of Smart Energy Meter Based on LoRaWAN in Campus Area</i>
	1D.2	135	<i>Interference Mitigation in Cognitive Radio Network Based on Grey Wolf Optimizer Algorithm</i>
	2G.4	599	<i>Application For Detection Of Pedestrian Position On Zebra Cross</i>
Muthchamy Sellamuthu, Karthika Devi	3E.4	721	<i>A Stacking Ensemble of Multi Layer Perceptrons to Predict Online Shoppers' Purchasing Intention</i>
Muttaqin, Didik	2D.3	463	<i>Speech Emotion Detection Using Mel-Frequency Cepstral Coefficient and Hidden Markov Model</i>
<b>N A B C D E F G H I J K L M N O P Q R S T U W X Y Z</b>			
N. Fathee, Hala	3B.4	655	<i>A Robust Iris Segmentation Algorithm Based on Pupil Region for Visible Wavelength Environments</i>
Nafi'iyah, Nur	3C.2	661	<i>The Use of Pre and Post Processing to Enhance Mandible Segmentation using Active Contours on Dental Panoramic Radiography Images</i>
Nagy, Adam	3A.3	632	<i>A bio-motivated vision system and artificial neural network for autonomous UAV obstacle avoidance</i>
Najmurokhman, Asep	2F.5	551	<i>Development of Temperature and Humidity Control System in Internet-of-Things based Oyster Mushroom Cultivation</i>
Nam, Andrew	1A.1	1	<i>Resource-Aware Pareto-Optimal Automated Machine Learning Platform</i>
Nasaruddin, Nasaruddin	2E.3	509	<i>Convolutional Network and Moving Object Analysis for Vehicle Detection in Highway Surveillance Videos</i>
Nashiruddin, Muhammad Imam	1F.6	251	<i>Performance Evaluation of XGS-PON Optical Network Termination for Enterprise Customer</i>
	1F.4	239	<i>Performance Evaluation of IPTV Multicast Service Testing for XGS-PON Optical Line Termination</i>
Nasr-Azadani, Mohamad	1A.1	1	<i>Resource-Aware Pareto-Optimal Automated Machine Learning Platform</i>

Nasri, Muhammad	<b>2B.1</b>	354	<i>The User Experience effect of Applying Floating Action Button (FAB) into Augmented Reality Anatomy Cranium Media Learning Prototype</i>
Nguyen-Quoc, Huy	<b>2D.1</b>	451	<i>Gender recognition based on ear images: a comparative experimental study</i>
Nivaan, Goldy Valendria	<b>1C.4</b>	106	<i>Analytic Predictive of Hepatitis using The Regression Logic Algorithm</i>
Noer, Astriany	<b>1G.4</b>	284	<i>Modification of 2.2 GHz S-Band Rectangular Patch Microstrip Antenna using Truncated Corner Method for Satellite Applications</i>
	<b>1G.5</b>	289	<i>Design of Optimal Satellite Constellation for Indonesian Regional Navigation System based on GEO and GSO Satellites</i>
NQ, Mohammad Arifin	<b>3A.2</b>	627	<i>Stemming Javanese: Another Adaptation of the Nazief-Adriani Algorithm</i>
Nugraha, Syechu	<b>2C.3</b>	412	<i>Design and Implementation of SVPWM Inverter to Reduce Total Harmonic Distortion (THD) on Three Phase Induction Motor Speed Regulation Using Constant V/F</i>
	<b>2C.2</b>	406	<i>Three Phase Induction Motor Dynamic Speed Regulation Using IP Controller</i>
Nugroho, Hanung	<b>2E.2</b>	499	<i>Supervised Deep Learning for Thyroid Nodules Classification Based on Margin Characteristic</i>
Nugroho, Lukito	<b>2G.3</b>	593	<i>Multi-Point Travel Destination Recommendation System In Yogyakarta Using Hybrid Location Based Service-Floyd Warshall Method</i>
	<b>2G.4</b>	599	<i>Application For Detection Of Pedestrian Position On Zebra Cross</i>
Nur, Darfiana	<b>2A.1</b>	310	<i>On Parameter Estimation of Stochastic Delay Difference Equation using the Two m-delay Autoregressive Coefficients</i>
Nurdewanto, B.	<b>1A.2</b>	7	<i>Blackbox Testing Model Boundary Value of Mapping Taxonomy Applications and Data Analysis of Art and Artworks</i>
Nurfadillah, Raditya	<b>2D.2</b>	457	<i>Benchmarking Explicit Rating Prediction Algorithms for Cosmetic Products</i>
Nurlina, Elin	<b>2F.5</b>	551	<i>Development of Temperature and Humidity Control System in Internet-of-Things based Oyster Mushroom Cultivation</i>

Nurmaini, Siti	1D.4	146	<i>Improving Classification Attacks in IOT Intrusion Detection System using Bayesian Hyperparameter Optimization</i>
Nurtiyasari, Devi	3C.3	667	<i>COVID-19 Chest X-Ray Classification Using Convolutional Neural Network Architectures</i>
Nurwarsito, Heru	1E.1	176	<i>Performance Analysis of Temporally Ordered Routing Algorithm Protocol and Zone Routing Protocol On Vehicular Ad-Hoc Network in Urban Environment</i>
Nusantara, Damai	2C.5	423	<i>Analysis of Performance Index in Transmission Expansion Planning of Sulawesi's Electricity System</i>
<b>O      A B C D E F G H I J K L M N O P Q R S T U W X Y Z</b>			
Octarina, Sisca	2A.1	315	<i>The N-Sheet Model in Capacitated Multi-Period Cutting Stock Problem with Pattern Set-Up Cost</i>
Oktian, Yustus	1E.3	187	<i>TwoChain: Leveraging Blockchain and Smart Contract for Two Factor Authentication</i>
Osman, Safaa	1B.7	68	<i>Risk Prediction of Major Depressive Disorder using Artificial Neural Network</i>
<b>P      A B C D E F G H I J K L M N O P Q R S T U W X Y Z</b>			
Perkasa, Gregorius	1D.2	135	<i>Interference Mitigation in Cognitive Radio Network Based on Grey Wolf Optimizer Algorithm</i>
Permana, Indra	2F.1	534	<i>Effect of Android and Social Media User Growth on the Financial Technology Lending Borrowers and its Financing</i>
Permanasari, Adhistya	2B.1	354	<i>The User Experience effect of Applying Floating Action Button (FAB) into Augmented Reality Anatomy Cranium Media Learning Prototype</i>
Petho, Mate	3A.3	632	<i>A bio-motivated vision system and artificial neural network for autonomous UAV obstacle avoidance</i>
Prakoso, Rahardi	1D.8	170	<i>Measurement of Information Security Awareness Level: A Case Study of Online Transportation Users</i>
Pramono, Subuh	2C.6	428	<i>Design and Development of Bit Error Measurement using FPGA for Visible Light Communication</i>
Prasetya, Suisbiyanto	1G.4	284	<i>Modification of 2.2 GHz S-Band Rectangular Patch Microstrip Antenna using Truncated Corner Method for Satellite Applications</i>
Prasetyawan, Purwono	2E.5	520	<i>Indonesian Traffic Sign Recognition For Advanced Driver Assistent (ADAS) Using YOLOv4</i>

Prasetyo, Wisnu	2A.8	348	<i>Students Academic Performance Prediction with k-Nearest Neighbor and C4.5 on SMOTE-balanced data</i>
Prasojo, Radityo Eko	2D.2	457	<i>Benchmarking Explicit Rating Prediction Algorithms for Cosmetic Products</i>
Pratama, Denni	1A.4	17	<i>Comparison of PSO, FA, and BA for Discrete Optimization Problems</i>
Pratama, Gilang	2B.2	360	<i>Development and Implementation of Kalman Filter for IoT Sensors: Towards a Better Precision Agriculture</i>
Pratama, Raditya	2G.3	593	<i>Multi-Point Travel Destination Recommendation System In Yogyakarta Using Hybrid Location Based Service-Floyd Warshall Method</i>
Pratama, Yogaswara	2G.1	577	<i>Case Study: AppDynamics Application as Business Intelligence to Support Digital Business Operations at PT PGD</i>
Pratiwi, Melati	3C.4	677	<i>Classification of Customer Actions on Digital Money Transactions on PaySim Mobile Money Simulator using Probabilistic Neural Network (PNN) Algorithm</i>
Priyadi, Ardyono	3E.3	716	<i>Energy Management Efficiency and Stability Using Passive Filter in Standalone Photovoltaic Sudden Cloud Condition</i>
Priyadi, Yudi	2A.5	332	<i>Extraction Dependency Based on Evolutionary Requirement Using Natural Language Processing</i>
Priyambodo, Tri	1F.1	221	<i>Designing Wireless Sensor Network Routing on Agriculture Area Using The LEACH Protocol</i>
	1D.1	129	<i>Real-time Testing on Improved Data Transmission Security in the Industrial Control System</i>
Prutphongs, Ponsuda	2G.2	588	<i>Decision Support System for Power Plant Improvement Investment Using Life-Cycle Cost</i>
Pujianto, Utomo	2A.8	348	<i>Students Academic Performance Prediction with k-Nearest Neighbor and C4.5 on SMOTE-balanced data</i>
Purnomo, Hindriyanto	1F.7	257	<i>Detection of Sensor Node-less Area Using A Genetic Algorithm for Wireless Sensor Network</i>
	3D.4	700	<i>A Modified Deep Convolutional Network for Covid-19 detection based on chest X-ray images</i>
Purwanto, Era	2C.3	412	<i>Design and Implementation of SVPWM Inverter to Reduce Total Harmonic Distortion (THD) on Three</i>

			<i>Phase Induction Motor Speed Regulation Using Constant V/F</i>
	<b>2C.2</b>	406	<i>Three Phase Induction Motor Dynamic Speed Regulation Using IP Controller</i>
Purwanto, Yudha	<b>1D.7</b>	164	<i>DDoS Attack Detection in Software Defined Network using Ensemble K-means++ and Random Forest</i>
Puspita, Fitri Maya	<b>2F.5</b>	556	<i>Modification of Wireless Reverse Charging Scheme with Bundling Optimization Issues</i>
Puspitasari, Novianti	<b>2D.7</b>	482	<i>Dayak Onion (<i>Eleutherine palmifolia</i> (L) Merr) as An Alternative Treatment in Early Detection of Dental Caries using Certainty Factor</i>
Putra, Agfianto	<b>1D.1</b>	129	<i>Real-time Testing on Improved Data Transmission Security in the Industrial Control System</i>
Putranto, Bambang Purnomosidi Dwi	<b>2B.6</b>	383	<i>A Comparative Study of Java and Kotlin for Android Mobile Application Development</i>
Putranto, Lesnanto Multa	<b>2C.5</b>	423	<i>Analysis of Performance Index in Transmission Expansion Planning of Sulawesi's Electricity System</i>
	<b>2C.1</b>	400	<i>Minimization of Power Losses through Optimal Placement and Sizing from Solar Power and Battery Energy Storage System in Distribution System</i>
Putri, Andi	<b>2C.4</b>	418	<i>The Single Tuned Filter Planning to Mitigate Harmonic Pollution in Radial Distribution Network Using Particle Swarm Optimization</i>
<b>Q      A B C D E F G H I J K L M N O P Q R S T U W X Y Z</b>			
Qomariyah, Nunung Nurul	<b>1C.8</b>	123	<i>Predicting User Preferences with XGBoost Learning to Rank Method</i>
Qudsi, Ony	<b>2C.3</b>	412	<i>Design and Implementation of SVPWM Inverter to Reduce Total Harmonic Distortion (THD) on Three Phase Induction Motor Speed Regulation Using Constant V/F</i>
	<b>2C.2</b>	406	<i>Three Phase Induction Motor Dynamic Speed Regulation Using IP Controller</i>
<b>R      A B C D E F G H I J K L M N O P Q R S T U W X Y Z</b>			
R., Christiono	<b>2C.4</b>	418	<i>The Single Tuned Filter Planning to Mitigate Harmonic Pollution in Radial Distribution Network Using Particle Swarm Optimization</i>
Rachmawaty, Dina	<b>1G.2</b>	272	<i>Techno-Economic 5G New Radio Planning at 26 GHz Frequency in Pulogadung Industrial Area</i>

Rahayu, Eny Sukani	1F.5	245	<i>Single Snapshot-Spatial Compressive Beamforming for Azimuth Estimation and Backscatter Reconstruction</i>
Ramadhan, Firdiansyah	2E.1	494	<i>Royale Heroes: A Unique RTS Game Using Deep Reinforcement Learning-based Autonomous Movement</i>
Ramadhani, Kurniawan	2E.3	505	<i>Combined Firefly Algorithm-Random Forest to Classify Autistic Spectrum Disorders</i>
Ratchagit, Manlika	2A.1	310	<i>On Parameter Estimation of Stochastic Delay Difference Equation using the Two m-delay Autoregressive Coefficients</i>
Rianti, Desi	1G.2	272	<i>Techno-Economic 5G New Radio Planning at 26 GHz Frequency in Pulogadung Industrial Area</i>
Ridhatama, Hasbi	2F.5	551	<i>Development of Temperature and Humidity Control System in Internet-of-Things based Oyster Mushroom Cultivation</i>
Rifa'i, Nanang	1G.7	301	<i>Disturbance Observer-Based Speed Estimator for Controlling Speed Sensorless Induction Motor</i>
Rifadil, Mochammad	2C.3	412	<i>Design and Implementation of SVPWM Inverter to Reduce Total Harmonic Distortion (THD) on Three Phase Induction Motor Speed Regulation Using Constant V/F</i>
	2C.2	406	<i>Three Phase Induction Motor Dynamic Speed Regulation Using IP Controller</i>
Riyadi, E. Hadiyono	1D.1	129	<i>Real-time Testing on Improved Data Transmission Security in the Industrial Control System</i>
Riyantoko, Prismahardi	2A.7	344	<i>Indonesian Stock Price Prediction including Covid19 Era Using Decision Tree Regression</i>
Robbi, Niki	1D.2	135	<i>Interference Mitigation in Cognitive Radio Network Based on Grey Wolf Optimizer Algorithm</i>
Romadhony, Ade	2D.8	488	<i>Aspect-based Opinion Mining on Beauty Product Reviews</i>
Rosadi, Dedi	3C.3	667	<i>COVID-19 Chest X-Ray Classification Using Convolutional Neural Network Architectures</i>
	1B.2	48	<i>Prediction of forest fire occurrence in peatlands using machine learning approaches</i>
Rosselina, Linda	1F.3	233	<i>Android Forensic Tools Analysis for Unsend Chat on Social Media</i>
Ruldeviyani, Yova	2G.1	577	<i>Case Study: AppDynamics Application as Business Intelligence to Support Digital Business Operations at PT PGD</i>



	1D.8	170	<i>Measurement of Information Security Awareness Level: A Case Study of Online Transportation Users</i>
Rusdiyanto, Dian	2F.7	567	<i>Comparison Of Eight Elements Array Structure Design For Coastal Surveillance Radar</i>
Rusli, Muhammad	2C.3	412	<i>Design and Implementation of SVPWM Inverter to Reduce Total Harmonic Distortion (THD) on Three Phase Induction Motor Speed Regulation Using Constant V/F</i>
<b>S A B C D E F G H I J K L M N O P Q R S T U V W X Y Z</b>			
S, Subaryono	2G.5	604	<i>Comparison of the Latest DTM with DEM Pleiades in Monitoring the Dynamic Peatland</i>
Sa'adah, Siti	1A.7	32	<i>Prediction of Gross Domestic Product (GDP) in Indonesia Using Deep Learning Algorithm</i>
	3C.4	677	<i>Classification of Customer Actions on Digital Money Transactions on PaySim Mobile Money Simulator using Probabilistic Neural Network (PNN) Algorithm</i>
Safitri, Eristya	2A.7	344	<i>Indonesian Stock Price Prediction including Covid19 Era Using Decision Tree Regression</i>
Sahmoud, Shaaban	3B.4	655	<i>A Robust Iris Segmentation Algorithm Based on Pupil Region for Visible Wavelength Environments</i>
Samudera, Satriya	2C.2	406	<i>Three Phase Induction Motor Dynamic Speed Regulation Using IP Controller</i>
Santoso, Fian	3D.4	700	<i>A Modified Deep Convolutional Network for Covid-19 detection based on chest X-ray images</i>
Sarjiya, Sarjiya	2C.5	423	<i>Analysis of Performance Index in Transmission Expansion Planning of Sulawesi's Electricity System</i>
	2C.1	400	<i>Minimization of Power Losses through Optimal Placement and Sizing from Solar Power and Battery Energy Storage System in Distribution System</i>
Sarwinda, Devvi	1A.6	26	<i>The Multimodal Transfer Learning for Diagnosing COVID-19 Pneumonia from Chest CT-Scan and X-Ray Images</i>
Sasmito, Adityan	1C.5	111	<i>Comparison of The Classification Data Mining Methods to Identify Civil Servants in Indonesian Social Insurance Company</i>
Sedyono, Eko	1F.7	257	<i>Detection of Sensor Node-less Area Using A Genetic Algorithm for Wireless Sensor Network</i>



Sendari, Siti	2B.4	371	<i>Development of The Personnel Monitoring System Using Mobile Application and Real-Time Database During the COVID19 Pandemic</i>
Setianingsih, Casi	2E.4	514	<i>Speaker Recognition For Digital Forensic Audio Analysis Using Support Vector Machine</i>
Setiawan, Florentinus Budi	2E.7	529	<i>Center of Gravity Method for Finding Center of Laser Beam Projection on Landslide Measurement</i>
Setijadi, Eko	1G.1	267	<i>A Combination of Defected Ground Structure and Line Resonator for Mutual Coupling Reduction</i>
Setya Budi, Avian Lukman	3E.3	716	<i>Energy Management Efficiency and Stability Using Passive Filter in Standalone Photovoltaic Sudden Cloud Condition</i>
Severin, Ionuț-Cristian	3C.3	672	<i>The Head Posture System Based on 3 Inertial Sensors and Machine Learning Models: Offline Analyze</i>
Shadieq, Nuur	1B.6	62	<i>Leveraging Side Information to Anime Recommender System using Deep learning</i>
Siahaan, Daniel	2A.5	332	<i>Extraction Dependency Based on Evolutionary Requirement Using Natural Language Processing</i>
Simbolon, Josua	1G.6	295	<i>Particle Filter Based Speed Estimator for Speed Sensorless Control in Induction Motor</i>
Sinaga, Frans	2A.4	326	<i>Optimization of SV-kNNC using Silhouette Coefficient and LMKNN for Stock Price Prediction</i>
Sirait, Pahala	2A.4	326	<i>Optimization of SV-kNNC using Silhouette Coefficient and LMKNN for Stock Price Prediction</i>
Siregar, Faisal	1B.8	73	<i>Hybrid Method for Flower Classification in High Intra-class Variation</i>
Siswantoro, Joko	3D.1	682	<i>Fruits Classification from Image using MPEG-7 Visual Descriptors and Extreme Learning Machine</i>
Siswantoro, Muhammad	3D.1	682	<i>Fruits Classification from Image using MPEG-7 Visual Descriptors and Extreme Learning Machine</i>
Soeprijanto, Adi	3E.3	716	<i>Energy Management Efficiency and Stability Using Passive Filter in Standalone Photovoltaic Sudden Cloud Condition</i>
Solihah, Nomarhinta	1F.6	251	<i>Performance Evaluation of XGS-PON Optical Network Termination for Enterprise Customer</i>
	1F.4	239	<i>Performance Evaluation of IPTV Multicast Service Testing for XGS-PON Optical Line Termination</i>

Sonalitha, Elta	1A.2	7	<i>Blackbox Testing Model Boundary Value of Mapping Taxonomy Applications and Data Analysis of Art and Artworks</i>
Sridhar, Sashank	3E.4	721	<i>A Stacking Ensemble of Multi Layer Perceptrons to Predict Online Shoppers' Purchasing Intention</i>
Stiawan, Deris	1D.4	146	<i>Improving Classification Attacks in IOT Intrusion Detection System using Bayesian Hyperparameter Optimization</i>
Suban, Ignasius	1C.3	100	<i>Influence Distribution Training Data on Performance Supervised Machine Learning Algorithms</i>
Subchan, Subchan	1G.8	306	<i>Ship Heading Control Using Nonlinear Model Predictive Control</i>
Subriadi, Apol	2F.2	539	<i>Consumer Behavior in Social Commerce Adoption: Systematic Literature Review</i>
Sudaryanto, Arif	2C.3	412	<i>Design and Implementation of SVPWM Inverter to Reduce Total Harmonic Distortion (THD) on Three Phase Induction Motor Speed Regulation Using Constant V/F</i>
Sudiharto, Indhana	1C.7	117	<i>Implementation of Maximum Power Point Tracking on PV System using Artificial Bee Colony Algorithm</i>
Sugianto, Sugianto	2A.6	338	<i>Multivariate Time Series Forecasting Based Cloud Computing For Consumer Price Index Using Deep Learning Algorithms</i>
Sulistiadi, Wahyu	2F.6	562	<i>Measuring Instagram Activity and Engagement Rate of Hospital: A Comparison Before and During COVID-19 Pandemic</i>
Sulistiyono, Mulia	1C.2	94	<i>The Best Parameter Tuning on RNN Layers for Indonesian Text Classification</i>
Sulistyo, Selo	1E.5	198	<i>Roadside Unit Power Saving using Vehicle Detection System in Vehicular Ad-hoc Network</i>
Sultoni, Arif	2F.8	572	<i>Implementation of Fuzzy-PID Based MPPT for Stand Alone 1.75 kWp PV System</i>
Sumadi, Fauzi	1D.5	152	<i>Comparative Analysis of DDoS Detection Techniques Based on Machine Learning in OpenFlow Network</i>
Sumiharto, Raden	1F.1	221	<i>Designing Wireless Sensor Network Routing on Agriculture Area Using The LEACH Protocol</i>

Suprpto, Bhakti	1D.4	146	<i>Improving Classification Attacks in IOT Intrusion Detection System using Bayesian Hyperparameter Optimization</i>
	3A.1	621	<i>Facial Expression Recognition and Face Recognition Using a Convolutional Neural Network</i>
Supriyanto, Eko	1B.8	79	<i>Personality Dimensions Classification with EEG Analysis using Support Vector Machine</i>
	1B.7	68	<i>Risk Prediction of Major Depressive Disorder using Artificial Neural Network</i>
Suryanto, Yohan	1F.3	233	<i>Android Forensic Tools Analysis for Unsend Chat on Social Media</i>
Susanto, Misfa	1F.8	262	<i>Performance Evaluation of Cell-Edge Femtocell Densely Deployed in OFDMA-Based Macrocellular Network</i>
Sussi, Sussi	1D.6	158	<i>Performance Analysis FSR and DSR Routing Protocol in VANET with V2V and V2I Models</i>
Sutivong, Daricha	2G.2	588	<i>Decision Support System for Power Plant Improvement Investment Using Life-Cycle Cost</i>
Suwadi, Suwadi	1E.4	192	<i>Performance Enhancement of Multi-User Key Extraction Scheme (MKES) Based on Imperfect Signal Reciprocity</i>
Suyanto, Suyanto	2D.4	467	<i>Firefly Algorithm-based Optimization of Base Transceiver Station Placement</i>
	2E.1	494	<i>Royale Heroes: A Unique RTS Game Using Deep Reinforcement Learning-based Autonomous Movement</i>
	1A.4	17	<i>Comparison of PSO, FA, and BA for Discrete Optimization Problems</i>
	2E.6	525	<i>Text-Independent Speaker Identification Using PCA-SVM Model</i>
	2D.3	463	<i>Speech Emotion Detection Using Mel-Frequency Cepstral Coefficient and Hidden Markov Model</i>
	1A.5	21	<i>PSO-Learned Artificial Neural Networks for Activity Recognition</i>
	2E.3	505	<i>Combined Firefly Algorithm-Random Forest to Classify Autistic Spectrum Disorders</i>
	3B.3	650	<i>Detection of Multi-Class Glaucoma Using Active Contour Snakes and Support Vector Machine</i>
	2D.6	476	<i>Topic-Based Tweet Clustering for Public Figures Using Ant Clustering</i>

	2D.5	471	<i>Removing Noise, Reducing dimension, and Weighting Distance to Enhance k-Nearest Neighbors for Diabetes Classification</i>
	3B.2	646	<i>Speech Gender Classification Using Bidirectional Long Short Term Memory</i>
Suyanto, Yohanes	1F.1	221	<i>Designing Wireless Sensor Network Routing on Agriculture Area Using The LEACH Protocol</i>
<b>T A B C D E F G H I J K L M N O P Q R S T U W X Y Z</b>			
Taheri, Sahar	1B.8	79	<i>Personality Dimensions Classification with EEG Analysis using Support Vector Machine</i>
Taufani, Agusta	2A.8	348	<i>Students Academic Performance Prediction with k-Nearest Neighbor and C4.5 on SMOTE-balanced data</i>
Truong Hoang, Vinh	2D.1	451	<i>Gender recognition based on ear images: a comparative experimental study</i>
Tung, Teresa	1A.1	1	<i>Resource-Aware Pareto-Optimal Automated Machine Learning Platform</i>
<b>U A B C D E F G H I J K L M N O P Q R S T U W X Y Z</b>			
Umam, Mohammad	1E.1	176	<i>Performance Analysis of Temporally Ordered Routing Algorithm Protocol and Zone Routing Protocol On Vehicular Ad-Hoc Network in Urban Environment</i>
Usman, U	2C.4	418	<i>The Single Tuned Filter Planning to Mitigate Harmonic Pollution in Radial Distribution Network Using Particle Swarm Optimization</i>
Uyun, Shofwatul	3D.3	694	<i>Feature Selection on Magelang Duck Egg Candling Image Using Variance Threshold Method</i>
<b>W A B C D E F G H I J K L M N O P Q R S T U W X Y Z</b>			
W, Bambang	1G.6	295	<i>Particle Filter Based Speed Estimator for Speed Sensorless Control in Induction Motor</i>
	1G.7	301	<i>Disturbance Observer-Based Speed Estimator for Controlling Speed Sensorless Induction Motor</i>
Wahyudi, Anung	2B.7	389	<i>Design and prototype development of internet of things for greenhouse monitoring system</i>
Wahyuni, Maria	2E.7	529	<i>Center of Gravity Method for Finding Center of Laser Beam Projection on Landslide Measurement</i>
Waluyo, Anita	2G.1	583	<i>Guided Genetic Algorithm to Solve University Course Timetabling with Dynamic Time Slot</i>

Wardhani, Shinta Amalia	2F.2	539	<i>Consumer Behavior in Social Commerce Adoption: Systematic Literature Review</i>
Wati, Masna	2D.7	482	<i>Dayak Onion (Eleutherine palmifolia (L) Merr) as An Alternative Treatment in Early Detection of Dental Caries using Certainty Factor</i>
Wibisono, Radityo	2C.7	433	<i>Optimization Coagulation Process of Water Treatment Plant Using Neural Network and Internet of Things (IoT) Communication</i>
Wibowo, Agung	1B.6	62	<i>Leveraging Side Information to Anime Recommender System using Deep learning</i>
Wibowo, Ferry Wahyu	1F.7	257	<i>Detection of Sensor Node-less Area Using A Genetic Algorithm for Wireless Sensor Network</i>
Wibowo, Muhammad	1A.7	32	<i>Prediction of Gross Domestic Product (GDP) in Indonesia Using Deep Learning Algorithm</i>
Widians, Joan	2D.7	482	<i>Dayak Onion (Eleutherine palmifolia (L) Merr) as An Alternative Treatment in Early Detection of Dental Caries using Certainty Factor</i>
Widiyatmoko, Dany	3A.2	627	<i>Stemming Javanese: Another Adaptation of the Nazief-Adriani Algorithm</i>
Widiyatmoko, Wahyu	1C.1	83	<i>Performance Comparison of Data Mining Techniques for Rain Prediction Models in Indonesia</i>
Widyawan, Widy	1D.2	135	<i>Interference Mitigation in Cognitive Radio Network Based on Grey Wolf Optimizer Algorithm</i>
Widyawati, Dewi	2B.7	389	<i>Design and prototype development of internet of things for greenhouse monitoring system</i>
Wijayanto, Danur	1F.1	221	<i>Designing Wireless Sensor Network Routing on Agriculture Area Using The LEACH Protocol</i>
Winarno, Edy	1C.1	83	<i>Performance Comparison of Data Mining Techniques for Rain Prediction Models in Indonesia</i>
Winursito, Anggun	2B.2	360	<i>Development and Implementation of Kalman Filter for IoT Sensors: Towards a Better Precision Agriculture</i>
Witono, Timotius	2F.4	545	<i>Analysis of Indonesia's Internet Topology Borders at the Autonomous System Level</i>
Wiwatanapataphee, Benchawan	2A.1	310	<i>On Parameter Estimation of Stochastic Delay Difference Equation using the Two m-delay Autoregressive Coefficients</i>
Wulandari, Eliandri	1F.4	239	<i>Performance Evaluation of IPTV Multicast Service Testing for XGS-PON Optical Line Termination</i>

X A B C D E F G H I J K L M N O P Q R S T U V W X Y Z

Xaphakdy, Khampaserth	1E.8	215	<i>Performance Enhancement in Macro-Femto Network Using a Modified Discrete Moth-flame Optimization Algorithm</i>
<b>Y A B C D E F G H I J K L M N O P Q R S T U W X Y Z</b>			
Yadav, Uma	2C.9	445	<i>Robust Control Design Procedure and Simulation of PRES Controller having Phase-Locked Loop(PLL) control technique in Grid-Tied Converter</i>
Yang, Yao	1A.1	1	<i>Resource-Aware Pareto-Optimal Automated Machine Learning Platform</i>
Yazid, Setiadi	2F.4	545	<i>Analysis of Indonesia's Internet Topology Borders at the Autonomous System Level</i>
Yudhantomo, Thomas	2C.5	423	<i>Analysis of Performance Index in Transmission Expansion Planning of Sulawesi's Electricity System</i>
Yudhistiro, Kukuh	1A.2	7	<i>Blackbox Testing Model Boundary Value of Mapping Taxonomy Applications and Data Analysis of Art and Artworks</i>
Yugopuspito, Pujianto	1C.1	89	<i>Website Design for Locating Tuna Fishing Spot Using Naïve Bayes and SVM Based on VMS Data on Indonesian Sea</i>
Yuliana, Mike	1E.4	192	<i>Performance Enhancement of Multi-User Key Extraction Scheme (MKES) Based on Imperfect Signal Reciprocity</i>
Yunanto, Prasti Eko	2D.5	471	<i>Removing Noise, Reducing dimension, and Weighting Distance to Enhance k-Nearest Neighbors for Diabetes Classification</i>
Yusran, Yusran	3D.2	688	<i>Unstructured Road Detection and Steering Assist Based on HSV Color Space Segmentation for Autonomous Car</i>
Yusrandi, Yusrandi	2B.4	371	<i>Development of The Personnel Monitoring System Using Mobile Application and Real-Time Database During the COVID19 Pandemic</i>
<b>Z A B C D E F G H I J K L M N O P Q R S T U W X Y Z</b>			
Zaeni, Ilham Ari	2B.4	371	<i>Development of The Personnel Monitoring System Using Mobile Application and Real-Time Database During the COVID19 Pandemic</i>
Zahara, Soffa	2A.6	338	<i>Multivariate Time Series Forecasting Based Cloud Computing For Consumer Price Index Using Deep Learning Algorithms</i>

Zainuddin, Zahir	<b>3D.2</b>	688	<i>Unstructured Road Detection and Steering Assist Based on HSV Color Space Segmentation for Autonomous Car</i>
Zeng, Shuai	<b>1A.2</b>	12	<i>Distributed Alternating Direction Multiplier Method Based on Optimized Topology and Nodes Selection Strategy</i>
Zsedrovits, Tamas	<b>3A.3</b>	632	<i>A bio-motivated vision system and artificial neural network for autonomous UAV obstacle avoidance</i>
Zubair, Anis	<b>1A.2</b>	7	<i>Blackbox Testing Model Boundary Value of Mapping Taxonomy Applications and Data Analysis of Art and Artworks</i>
Zulfira, Fakhira	<b>3B.3</b>	650	<i>Detection of Multi-Class Glaucoma Using Active Contour Snakes and Support Vector Machine</i>
Zulkifli, Fitri	<b>1E.7</b>	209	<i>Development of Smart Energy Meter Based on LoRaWAN in Campus Area</i>

# Comparative Analysis of DDoS Detection Techniques Based on Machine Learning in OpenFlow Network

Fauzi Dwi Setiawan Sumadi  
Informatics Department  
Universitas Muhammadiyah Malang  
Malang, Indonesia  
fauzisumadi@umm.ac.id

Christian Sri Kusuma Aditya  
Informatics Department  
Universitas Muhammadiyah Malang  
Malang, Indonesia  
christianskaditya@umm.ac.id

**Abstract**— Software Defined Network (SDN) allows the separation of a control layer and data forwarding at two different layers. However, centralized control systems in SDN is vulnerable to attacks namely distributed denial of service (DDoS). Therefore, it is necessary for developing a solution based on reactive applications that can identify, detect, as well as mitigate the attacks comprehensively. In this paper, an application has been built based on machine learning methods including, Support Vector Machine (SVM) using Linear and Radial Basis Function kernel, K-Nearest Neighbor (KNN), Decision Tree (DTC), Random Forest (RFC), Multi-Layer Perceptron (MLP), and Gaussian Naïve Bayes (GNB). The paper also proposed a new scheme of DDoS dataset in SDN by gathering considerably static data form using the port statistic. SVM became the most efficient method for identifying DDoS attack successfully proved by the accuracy, precision, and recall approximately 100 % which could be considered as the primary algorithm for detecting DDoS. In term of the promptness, KNN had the slowest rate for the whole process, while the fastest was depicted by GNB.

**Keywords**—SDN, Machine Learning, DDoS, Detection, Reactive

## I. INTRODUCTION

The development of computer network technology is pushing some of the core sectors in the network to make radical changes in order to meet the trends of computer networks that are needed today including agile, flexible, and versatile. One common problem that must be analysed carefully is network management. With the continued increase in computer network devices (Internet of Things), efforts in managing network traffic will increase linearly. In a traditional computer network, a network administrator must manually configure each layer 2 and layer 3 device if there are problems with the device. This must be done because there are different configurations set by each network device vendor with specific procedures [1]. For example, to configure a router with a Cisco vendor it will be different from a Juniper router. Complex computer network trends can trigger misconfiguration or human errors.

In order to resolve the specified problems, computer network paradigm was developed called SDN. SDN separates vertical abstractions in traditional network devices consisting of 2 core layers, the controller layer and the forwarding layer [2]. The controller acts as the centre of the network settings that are connected directly to the device. Various network management functions can be flexibly

managed by installing applications, for example, the routing process, the mapping of network topology, the intrusion detection system, the discovery of the Internet Protocol (IP), the discovery of the Address Resolution Protocol (ARP), and other special functions built with program lines in the application layer on the controller. The application that has been installed in the controller will process each incoming packet and respond according to the algorithm that has been defined. There is a southbound API protocol that functions to standardised the communication so that the layer forwarding device can perform the forwarding function compiled by the controller.

The implementation of a centralized control system provides a security loophole that can be exploited by irresponsible parties to be able to carry out attacks aimed at broadly impacting the topology that is directly connected to a controller. One example of an attack that can be carried out both locally and globally is DDoS. This type of attack can saturate links that are connected directly to the controller. The controller will indirectly process the incoming new packet to the topology. This is a major weakness in implementing a centralized control system. With the number of new packages that exceed the normal limit will force the controller to process the package by utilizing all available resources so that it can bring the controller in an unstable condition.

Several methods have been implemented before by integrating machine learning. However, its implementation is only based on the process of detection and identification of attacks and used the available dataset that did not maintain the feature specifically for SDN environment. In the process of detection, several previous studies applied a proactive scheme by utilizing flow integration tools for packet headers without involving controllers. But in this method, there are still scalability issues where the system can only be implemented on forwarding devices that have adequate resources. [3] using the C4.5 algorithm, Bayesian Network, Decision Table, and Naïve Bayes in the DDoS detection process. The system is developed reactively by providing certain IP subnet block actions, with a dataset that has 4 features, including, the IP of the attacker, the destination host, the attack number, and the timestamp of the attack. This research has not discussed in detail the port and protocol-based attacks. In research [4], the authors used the SVM, Naïve Bayes, and Neural Network methods to identify DDoS attacks with a selection feature based only on the number of hosts making requests every second without using IP and



protocol. Whereas in [5], the authors compared several classification methods with datasets obtained from DARPA without mitigating and were not accompanied by a description of the mechanism of comparison of the use of methods to the use of existing resources in SDN. Moreover, in [6] the authors created an ML server which could extract the dataset from the controller based on the NL-KDD dataset which gained 98% in accuracy and defend proactively. [7] proposed machine learning and deep learning detection without implementing the mitigation method for SDN. The authors used NSL-KDD dataset which gained accuracy of 88% for Deep Neural Network method. [8] used the combination of 3 distinct available online datasets where the feature extracted using sFlow gained 96.5% for the detection rate utilising Random Forest Algorithm.

In different mechanism, several papers conducted their experiment by using their own dataset extraction process which was considered compatible with the SDN environment such as flow rule statistic. Paper [9] used sFlow dockers to extract the flow data from the SDN switches and utilised the feature extraction process gaining 98.3% accuracy for the KNN classifier. [10] proposed an almost similar pattern of a dataset, using 4 main features (flow length, flow duration, flow size, and flow ratio). The researchers developed an improved KNN method and achieved around 99.4% for the recall variable. Moreover, paper [11] also implemented flow stat request for generating 6 features as the main resource to classify using SVM resulting 95.24% for the accuracy of the detection rate. In similar pattern, paper [12] used the flow statistic mechanism for developing dataset features in nmeta2 architecture which then classified by using SVM, KNN, and Random Forest. The highest accuracy depicted by KNN at around 93.5%.

Based on the previous research that has been done before, this research was focused to develop and analyse applications to detect, identify, and mitigate DDoS attacks on SDN networks from various machine learning classification methods including, RBF SVM, Linear SVM, KNN, DTC, RFC, MLP, and GNB reactively. This research also proposed new feature scheme for the dataset which could create an almost static form of dataset increasing to the accuracy variable. Later, each method will be analysed based on the accuracy of the detection and mitigation results as well as the accumulative data of resource usage from the controller when running the application. In addition, the application will implement the DDoS mitigation scheme by utilizing the priority rule feature provided by the OpenFlow standard. So packets that are classified as malicious packets will automatically be blocked. The details of the application scheme method and the research method are explained further in the research method section.

## II. RESEARCH METHOD

The research was emulated using Mininet [13] as the emulator software. The topology consisted of three main SDN OvS switches [14], one RYU [15] controller as the centre of the networking management process, and six Hosts. Fig. 1 illustrates the overview of the specified topology. The main concern of the attacker was directed to perform a DDoS attack directly to the controller by sending randomly generated data test packets. The H1 acted as the attacker by sending a large number of packets to the H4.

The controller by default implemented learning switch mechanism for mapping the network environment. The flow of the proposed reactive machine learning application is described in Fig. 2 and Fig. 3. Upon receiving new packets, the switch will directly filter the packet's header with the available flow selector installed on the switch. If there is no packet's selector that can filter the incoming packet the switch will encapsulate the incoming packet in OPFT\_PACKET\_IN message to the controller [16].

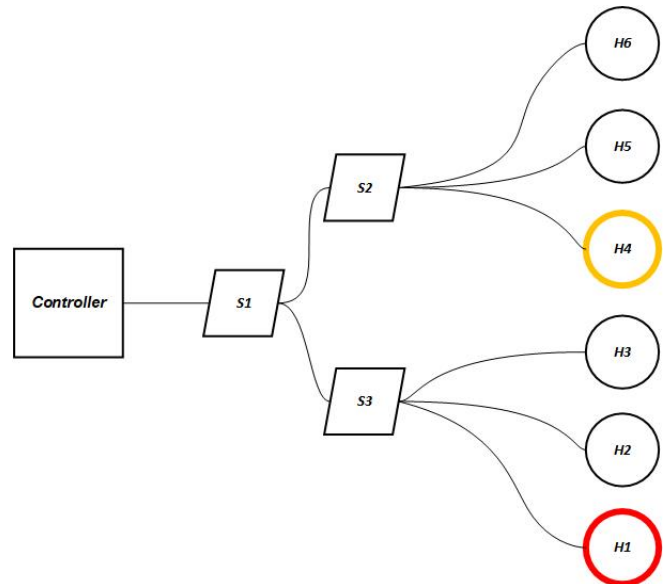

Fig. 1. Emulation's topology

Since the construction of the packet consisted of either random source port or IP source, the SDN switch would automatically forward the incoming DDoS packet to the controller for further assessment. Otherwise, the SDN switch will perform the traffic treatment specified by the controller, such as forwarding, dropping, crafting, etc.

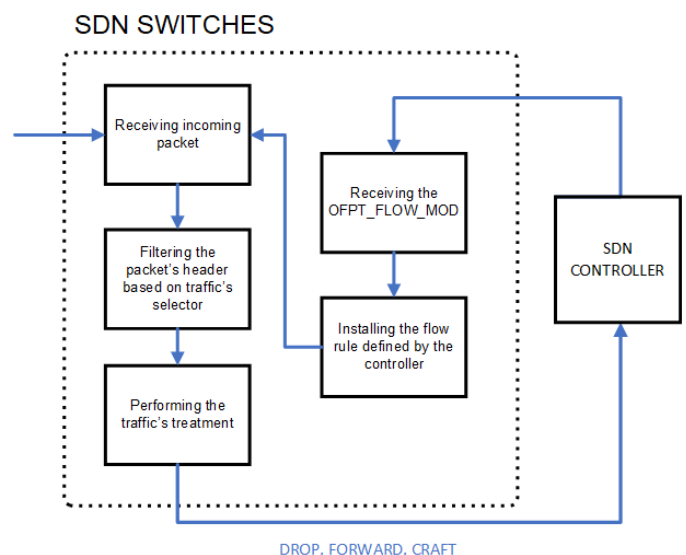

Fig. 2. SDN switch's block diagram

After the controller receiving the OFPT\_PACKET\_IN message, the machine learning app will parse the packet's header corresponding to the list of features used on the

classification model (the details are explained in section III). Subsequently, the application processes the header's information and converts it into float format using a standard scaler. Furthermore, the application applies the classification model to predict the result of the current packet's header information. If the result states that the packet is considered as the normal packet, the application will transfer the packet processing mechanism to learning switch application. On the other hand, if the packet is identified as DDoS packet, the controller creates OFPT\_FLOW\_MOD message consists of flow rule construction command for blocking the DDoS attack based on the identified protocol's type then sends it to the corresponding SDN switch (directly connected to the attacker). Therefore, the attack will be blocked or dropped by the SDN switch using an idle time period (60s).

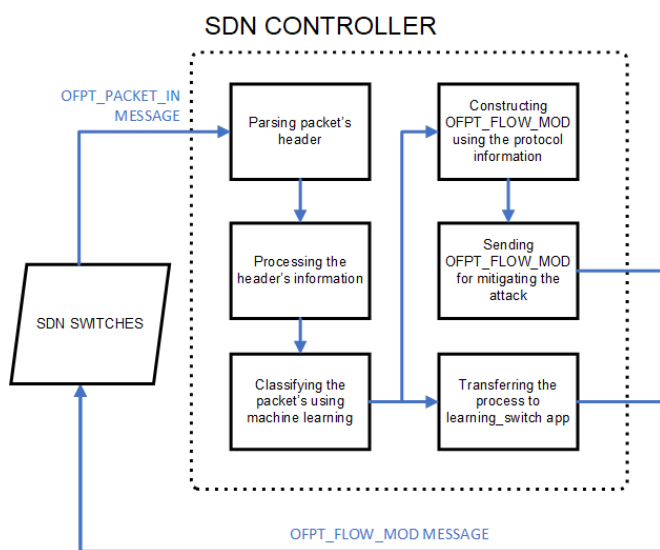

Fig. 3. SDN controller's block diagram

The classification algorithms that were used during the experiment consisted of RBF SVM, Linear SVM, KNN, DTC, RFC, MLP, QDA, and GNB. Each of the algorithms has its own hyperparameter which is illustrated in Table I. In order to analyse the effectiveness of the specified algorithms, several variables were used to measure which was the most accurate algorithm for classifying DDoS attack. The variables included accuracy, precision, recall, and F1 score.

TABLE I. HYPERPARAMETERS USED IN CLASSIFICATION

Algorithm	Hyperparameters
RBF SVM	Kernel: RBF Kernel Coefficient: 0.01 Lambda: 10
Linear SVM	Kernel: Linear Function Lambda: 0.025
KNN	Number of Neighbours: 2 Weight Function: Uniform Computational Algorithm: Brute-Force
DTC	Split Function: Gini Information Gain: Entropy Maximum Tree's Depth: 5
RFC	Number of Trees: 10 Split Function: Gini Information Gain: Entropy Maximum Tree's Depth: 5

Algorithm	Hyperparameters
MLP	Hidden Layer: 1 Activation Function: Relu Solver: Adam Maximum Iteration: 200
ADC	Maximum Number of Estimator: 50 Boosting Algorithm: SAMME.R
GNB	the largest variance: 1e-09 Prior Probabilities: Adjusted Based on Data

### III. RESEACH DATASET

Instead of using flow statistic data which was introduced in [9-12], the experiment was carried out using different dataset structure that could be categorized as a static form of data. The dataset can be found in [17]. The data extraction process used the IPv4, ICMP, TCP, and UDP header information added by some information regarding to the port's statistic extracted from the reply of OFPMP\_PORT\_STATS requests. The list of features is described in Table II.

TABLE II. FEATURE LIST

Feature's Name	Feature's Origin
datapath_id	OFPT_PACKET_IN
version	IPv4's Header
header_length	IPv4's Header
tos	IPv4's Header
total_length	IPv4's Header
flags	IPv4's Header
offset	IPv4's Header
ttl	IPv4's Header
proto	IPv4's Header
csum	IPv4's Header
src_ip	IPv4's Header
dst_ip	IPv4's Header
src_port	UDP's/TCP's Header
dst_port	UDP's/TCP's Header
tcp_flag	TCP's Header
type_icmp	ICMP's Header
code_icmp	ICMP's Header
csum_icmp	ICMP's Header
port_no	OFPPortStatsReply
rx_bytes_ave	OFPPortStatsReply (rx_bytes / rx_packets)
rx_error_ave	OFPPortStatsReply (rx_errors / rx_packets)
rx_dropped_ave	OFPPortStatsReply (rx_dropped / rx_packets)
tx_bytes_ave	OFPPortStatsReply (tx_bytes / tx_packets)
tx_error_ave	OFPPortStatsReply (tx_errors / tx_packets)
tx_dropped_ave	OFPPortStatsReply (tx_dropped / tx_packets)

Data extraction process (Fig. 4) started from the attacker by sending two \*.pcap files that contained the train data and test data. The flooding process was performed individually for both files. The authors configured the SDN switches for

passing the incoming packet directly to the controller. Simple switch application in RYU had been extended as well in order to retrieve the packet's header information –

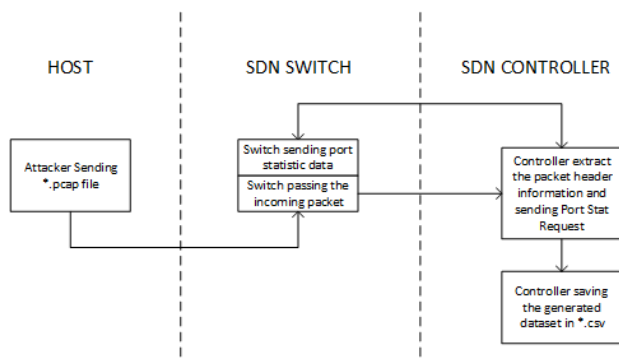

Fig. 4. Dataset extraction process

concerning the IPv4, TCP, UDP, and ICMP as well as sending OFPPortStatsRequest to the corresponding switch for acquiring the port statistic. The average number of bytes of the incoming packet was calculated by differentiating the number of bytes received and the number of packets received (rx\_bytes\_ave). The attack was conducted by sending 3 distinct types of attacks including the ICMP, TCP, and UDP flood attack. The available class consisted of 6 class which included the DDOS\_ICMP, DDOS\_TCP, DDOS\_UDP, NORMAL\_ICMP, NORMAL\_TCP, and NORMAL\_UDP. In term of the data proportion, the number of train data is 420,000 data while the test data is divided into two distinct number including the 18,000 and 36,000 data tests. Both data types (train and test) were generated on different occasion and consisted of different structures.

#### IV. RESULTS AND DISCUSSION

The experiment's results showed several variables that could be used to measure the capability of each proposed algorithm for detecting and identifying the DDoS attack. Table III showed the training time for each algorithm to create the classifier model based on two distinct data proportion (420,000:18,000 and 420,000:36,000). The longest time was depicted by KNN followed by MLP and SVM respectively while the other algorithms could finish the model before or equal to 1 s. This behaviour might occur since the SVM used Linear and RBF kernel which were considered as the complex kernel. KNN also took a considerably long time to develop a model because of the calculation of the distance between data point.

TABLE III. TRAINING TIME

Classifier Type	Training Time (s)
SVM (RBF)	6.514
SVM (LIN)	3.085
KNN	85.781
DTC	1
RFC	0.7
MLP	18.971
GNB	0.1

Moreover, the experiment was conducted into two different scenarios which included the prediction scheme without involving the SDN controller and generating the prediction using the SDN controller. In term of the first scenario portrayed by Table VI and Table V, the accuracy for DTC were decreasing because the uniformity of data test dropping along with the growth of the number of data test. The positive trend illustrated by SVM, KNN, RFC, MLP, and GNB. The results showed the highest accuracy depicted by both Linear SVM and GNB for all data test size. However, this trend was not described in the second scenario due to data redundancy.

TABLE IV. EXPERIMENT'S RESULT FOR 18000 DATASET WITHOUT SDN

Classifier Type	Accuracy (18000) %	Precision (18000) %	Recall (18000) %	F1 (18000) %
SVM (RBF)	99.3	99.3	99.3	99.3
SVM (LIN)	99.9	99.9	99.9	99.9
KNN	99	99	99	99
DTC	100	100	100	100
RFC	69.5	80	69.5	62.7
MLP	35.6	33.2	35.6	22.3
GNB	99.7	99.7	99.7	99.7

TABLE V. EXPERIMENT'S RESULT FOR 36000 DATASET WITHOUT SDN

Classifier Type	Accuracy (36000) %	Precision (36000) %	Recall (36000) %	F1 (36000) %
SVM (RBF)	100	100	100	100
SVM (LIN)	100	100	100	100
KNN	99.4	99.4	99.4	99.4
DTC	83.3	75	83.3	77.7
RFC	97	97.5	97	97
MLP	50.4	50.4	50.4	50.4
GNB	100	100	100	100

Surprisingly, the pattern did not occur for some classification algorithm on the second scenario since the prediction results appeared to be redundant. This circumstance might occur because there was a lot of feature processing mechanism that should be maintained by the SDN controller. Therefore, the percentage of prediction loss was pointed at around 79.8% for 36,000 data tests which meant only 7,272 data successfully classified illustrated in Table VIII. In details, the algorithm that could maintain its accuracy variable was RBF SVM and Linear SVM approximately at 100% indicating that the increase of the data test did not reduce the robustness of the classification process (Table VI and Table VII). The increasing trend in accuracy also produced by KNN. The remaining algorithms including DTC, RFC, MLP, and GNB generated a decreasing percentage for all variables which indicated that the algorithms could not handle the classification efficiently.

TABLE VI. EXPERIMENT'S RESULT FOR 18000 DATASET IN SDN

Classifier Type	Accuracy (18000) %	Precision (18000) %	Recall (18000) %	F1 (18000) %
SVM (RBF)	100	100	100	100

Classifier Type	Accuracy (18000) %	Precision (18000) %	Recall (18000) %	F1 (18000) %
SVM (LIN)	100	100	100	100
KNN	87.8	93.1	88.2	86.5
DTC	100	100	100	100
RFC	84.2	86.4	84.6	83.1
MLP	34.5	32.5	36.3	23
GNB	93.9	95	94.1	93.5

TABLE VII. EXPERIMENT'S RESULT FOR 36000 DATASET IN SDN

Classifier Type	Accuracy (36000) %	Precision (36000) %	Recall (36000) %	F1 (36000) %
SVM (RBF)	100	100	100	100
SVM (LIN)	100	100	100	100
KNN	95.6	89.2	92.9	87.5
DTC	89.7	78.4	83.3	80.4
RFC	80.7	88.4	84.4	82.5
MLP	65.3	52.4	66.6	54.2
GNB	59.1	68.6	83.1	70

TABLE VIII. PERCENTAGE OF PREDICTION LOSS IN SDN

Classifier Type	Prediction Loss (18000) in %	Prediction Loss (36000) in %
SVM (RBF)	2.7	79.8
SVM (LIN)	2.7	79.8
KNN	2.7	79.8
DTC	2.7	79.8
RFC	2.7	79.8
MLP	2.7	79.8
GNB	2.7	79.8

In addition, Table IX shows the most significant features (top 10) that influences the classification process. The selection was done by utilizing Random Forest Regressor. The Table also informs the source of the feature which mainly are extracted from IPv4's packet header as well as the data from sending OFPMP\_PORT\_STATS message directly to the SDN controller.

TABLE IX. TOP 10 FEATURES FOR CLASSIFICATION

Feature Name	Feature's Source
total_length	IPv4
ttl	IPv4
proto	IPv4
csum	IPv4
src_ip	IPv4
src_port	IPv4
dst_port	IPv4
tcp_flag	IPv4
port_no	Port_Stat
rx_bytes_ave	Port_Stat

## V. RESULTS AND DISCUSSION

Overall, DDoS still became one of the most significant issues in SDN in regard to centralized control management. The authors proposed new scheme of dataset which utilized the packet's library and the port statistic request for extracting 25 features in total. Machine learning methods was comparatively analyzed and can be deduced that the SVM whether used the Linear or RBF kernel could produce the highest accuracy among several similar researches. The authors will try to analyze the significance of Deep Learning method for detecting the similar attacks in the future.

### ACKNOWLEDGMENT

The authors would like to say their profound gratitude for the Universitas Muhammadiyah Malang as the main sponsor for this research.

### REFERENCES

- [1] Sezer S, Scott-Hayward S, Chouhan PK, Fraser B, Lake D, Finnegan J, et al. Are we ready for SDN? Implementation challenges for software-defined networks. *IEEE Communications Magazine*. 2013;51(7):36-43.
- [2] Software Defined Networking: The Norm For Networks (2012).
- [3] Nanda S, Zafari F, DeCusatis C, Wedaa E, Yang B, editors. Predicting network attack patterns in SDN using machine learning approach. 2016 IEEE Conference on Network Function Virtualization and Software Defined Networks (NFV-SDN); 2016 7-10 Nov. 2016.
- [4] Meti N, Narayan DG, Baligar VP, editors. Detection of distributed denial of service attacks using machine learning algorithms in software defined networks. 2017 International Conference on Advances in Computing, Communications and Informatics (ICACCI); 2017 13-16 Sept. 2017.
- [5] Kokila RT, Selvi ST, Govindarajan K, editors. DDoS detection and analysis in SDN-based environment using support vector machine classifier. 2014 Sixth International Conference on Advanced Computing (ICoAC); 2014 17-19 Dec. 2014.
- [6] Mohammed SS, Hussain R, Senko O, Bimaganbetov B, Lee J, Hussain F, et al., editors. A New Machine Learning-based Collaborative DDoS Mitigation Mechanism in Software-Defined Network. 2018 14th International Conference on Wireless and Mobile Computing, Networking and Communications (WiMob); 2018 15-17 Oct. 2018.
- [7] Dey KS, Rahman MM. Effects of Machine Learning Approach in Flow-Based Anomaly Detection on Software-Defined Networking. *Symmetry*. 2019;12(1).
- [8] Lima Filho FS de, Silveira FAF, de Medeiros Brito Junior A, Vargas-Solar G, Silveira LF. Smart Detection: An Online Approach for DoS/DDoS Attack Detection Using Machine Learning. Maglaras L, editor. *Secur Commun Networks [Internet]*. 2019;2019:1574749. Available from: <https://doi.org/10.1155/2019/1574749>
- [9] Polat H, Polat O, Cetin A. Detecting DDoS Attacks in Software-Defined Networks Through Feature Selection Methods and Machine Learning Models. *Sustainability*. 2020;12(3).
- [10] Dong S, Sarem M. DDoS Attack Detection Method Based on Improved KNN With the Degree of DDoS Attack in Software-Defined Networks. *IEEE Access*. 2020;8:5039-48.
- [11] Ye J, Cheng X, Zhu J, Feng L, Song L. A DDoS Attack Detection Method Based on SVM in Software Defined Network. Cai Z, editor. *Secur Commun Networks [Internet]*. 2018;2018:9804061. Available from: <https://doi.org/10.1155/2018/9804061>
- [12] Bakker JN, Ng B, Seah WKG, editors. Can Machine Learning Techniques Be Effectively Used in Real Networks against DDoS Attacks? 2018 27th International Conference on Computer Communication and Networks (ICCCN); 2018 30 July-2 Aug. 2018.
- [13] Mininet. Online [Available from: Available: <http://mininet.org/>].
- [14] vSwitch O. Online [Available from: <http://openswitch.org/>].
- [15] RYU. Online [Available from: <https://osrg.github.io/ryu/>].
- [16] OpenFlow Switch Specification (Version 1.3.0), (2012).

[17] Housman, Oxicusa Gugi; Isnaini, Hafida; Sumadi, Fauzi Dwi Setiawan (2020), "SDN-DDOS (ICMP,TCP,UDP)", Mendeley Data,

V2, doi: 10.17632/hkjb67rsc.2