

RESEARCH ARTICLE | MARCH 26 2024

Preface: 2nd International Conference on Technology, Informatics, and Engineering **FREE**



AIP Conf. Proc. 2927, 010001 (2024)

<https://doi.org/10.1063/1.2023947>



AIP Advances

Why Publish With Us?

- 25 DAYS**
average time to 1st decision
- 740+ DOWNLOADS**
average per article
- INCLUSIVE**
scope

[Learn More](#)

Preface: 2nd International Conference on Technology, Informatics, and Engineering

The International Conference on Technology, Informatics, and Engineering (Icon-TINE) is an annual scientific conference organized by the Engineering Faculty, University of Muhammadiyah Malang. In 2nd Icon-TINE 2022, this conference was held Hybrid Conference with attracts both in-person attendees/face-to-face and virtual/online attendees via Video Conference (for the keynote speaker) and record presentation for the invited presenter and presenter. More than 140 papers have been submitted from various research and educational institutions around the world (India, Indonesia, Taiwan, and Malaysia). The advancement of technological approaches and engineering methods may simplify the existing problems from previous findings. The original notions from the researcher may inspire the other experts to develop, modify, or even combine the proposed method with the existing method for resulting in more efficient procedures. Therefore, Icon-TINE aims to provide a platform for researchers, scholars, and practitioners to discuss and present their latest findings corresponding to their field of expertise. This conference provides opportunities for the delegates to exchange new ideas face-to-face to bring together leading academic scientists, researchers, and research scholars to exchange and share their experiences and research results on all aspects of engineering, science, and technology. We hope that the conference results will lead to significant contributions to the knowledge in these up-to-date scientific fields.

The conference addressed the practical engineering application (Mechatronics & robotics, Computational Intelligence, Data Science, Computer Science, Electrical and Control Engineering, Statistical Physics and Nonlinear Systems, Instrumentation and Measurement, Mathematical Physics, Biological Physics, Chemical Physics and Physical Chemistry, Condensed Matter: Electrical, Magnetic and Optical), Mechanical Engineering, Civil Engineering, dan Industrial Engineering.

RESEARCH ARTICLE | MARCH 26 2024

The application of building information modelling (BIM) for cost and time analysis: Bintang Bano Dam, West Sumbawa, Indonesia **FREE**

A. Apriadi ; Moh Abduh; Rini Pebri Utari



AIP Conf. Proc. 2927, 030012 (2024)

<https://doi.org/10.1063/5.0192688>

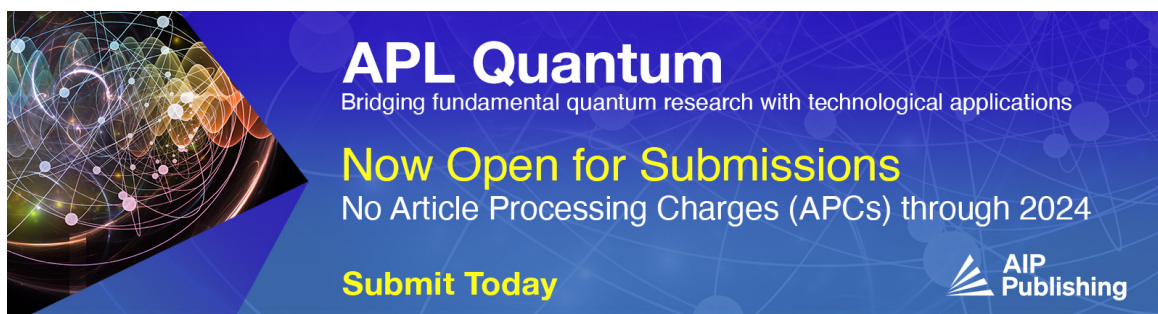

APL Quantum
Bridging fundamental quantum research with technological applications

Now Open for Submissions
No Article Processing Charges (APCs) through 2024

Submit Today



The Application of Building Information Modelling (BIM) for Cost and Time Analysis: Bintang Bano Dam, West Sumbawa, Indonesia

A Apriadi^{a)}, Moh Abduh, Rini Pebri Utari

Department of Civil Engineering, Universitas Muhammadiyah Malang, Malang, Indonesia

^{a)}Corresponding author: abduh@umm.ac.id

Abstract. Construction projects often have problems with costs, quality, time, and design errors from the planning period to the construction time. This is because construction projects in Indonesia still use traditional methods. This research focuses on the use of the method in the field of construction management, namely Building Information Modeling. This study used 3D modeling software to create a simulation of the spillway structure and generate cost and work volume data. Then, using scheduling software, it determined the duration of the work. The study found that using BIM methods is more time-consuming than conventional methods, which is a cost difference of (IDR) 39,653,431.49. The duration of the work obtained on the 4D BIM model is 540 days. The use of BIM can be said to be more effective and efficient because BIM can calculate the volume of work in geometric conditions that are more difficult and detailed.

Keywords: Building Information Modelling, Quantity Take Off, Time Schedule

INTRODUCTION

Construction industry development is currently expanding quickly. This is because the construction industry is a very important part of advancing a country. The growth of construction in Indonesia is evident in the sheer volume of significant projects undertaken by both the public and private sectors [1]. (a) Construction projects require careful planning, good control, and careful implementation, and good information delivery is needed to all related parties. (b) Construction projects require qualified personnel, the availability of materials, environmental factors, and geographic location. [2].

Construction projects often have problems from the planning stage to the construction stage, one of which is in terms of cost, time, and design errors [3]. This is because it is still using conventional methods [4]. The management process must evolve more quickly and efficiently to keep up with changes and demands in the construction industry. This process can also lessen miscommunication between parties and help prevent construction mistakes [5]. Such problems also occur in the Bintang Bano Dam construction project in West Sumbawa Regency. This project needs special attention, thoroughness, and good coordination at every stage related to Architecture, Engineering, and Construction (AEC) [6]. One of the construction management methods that can reduce errors in construction is the Building Information Modeling (BIM) method [7].

BIM is a method that is currently being developed in the fields of Architecture, Engineering, and Construction (AEC). When using the BIM method, we are able to visualize a construction project into a 3-dimensional (3D) model, so that better analysis and control can be carried out than with conventional methods [8]. The created model includes geometry and data that can assist with fabrication, procurement, and construction activities from the project's inception through realization [5].

The use of the BIM method can make it easier for project managers to control and analyze ongoing projects [9]. BIM can minimize and control building performance directly, both in terms of cost and duration of project work, and is able to identify problems that occur, such as design planning, because BIM can produce 3D models that are interconnected between work items [10].

In 2014, a study was conducted on the comparison between the use of the BIM method and the conventional method to control construction costs. In his study the researchers concluded that the use of conventional methods from the point of view of using software is quite easy to understand and does not require a long time to use the BIM method.

Although from an operational point of view, the BIM method takes longer and is more complicated, but the BIM method guarantees the accuracy of the model and the accuracy in its calculations [11].

A similar study was also conducted in 2016, where the research focused on comparing the amount of reinforcement produced using the conventional method with the BIM method. The study concluded that the amount of rebar obtained using the conventional method was 17.76% more than using the BIM method [12]. In 2020, there was a study concluded that the use of the BIM method had better performance than conventional methods to determine the estimated cost of a construction project. The use of BIM-based methods is also faster, easier, efficient, automated, and allows for fewer errors [13].

In this study, an analysis will be carried out to determine the difference in costs obtained between using the conventional method and the BIM method, as well as to generate the total duration of work from the 4D BIM method. This study has differences with previous research. Where in previous studies only compared in terms of costs, but in this study the authors added the use of the BIM method to analyze construction time. This is intended to determine the efficiency and effectiveness of the use of the BIM method in construction project management and to provide an illustration that in one method BIM is able to control costs, time and quality better than conventional methods.

METHODS

This study was conducted by means of simulation, which aims to find a picture through a model, and control manipulation will be carried out to see the effect. In the modeling process, software that can create 3D models and software that can create schedules is needed.

In the analysis process, this study requires data in the form of Detailed Engineering Design (DED) drawings, the volume of concrete and reinforcement, duration of work, and unit prices. This dam's spillway structure data is broken up into 4 sections, each of which uses concrete with an $F_c' = 22$ MPa quality rating. For details of the spillway structure, see **TABLE 1**.

TABLE 1. Detail Structure of Spillway

No	Blok	Blok	Fc'
1	Segment 1	1A, 2A, 3A, 4A, 5A, 6A, dan 7A	22 MPa
2	Segment 2	Pier 1, Pier 2, Pier 3, Pier 4, Control threshold	22 MPa
3	Segment 3	A, B, C, D, E, F, G, H, I, J, K, L, M, N, O, P, Q, R, dan S	22 MPa
4	Segment 4	T, U, V, W, X dan Y	22 MPa

Source: Bintang Bano Dam Construction Project

RESULTS AND DISCUSSION

After sorting/grouping on this BIM, the results will be in the form of a volume according to the specified shield as shown in **FIGURE 1**

<QUANTITY TAKE OFF CONCRETE>						
A	B	C	D	E	F	G
Work Item	Segment	Block	Fc'	Volume	Cost	Total Cost
Concrete	Segment 1	Block A1	Fc' 22 Mpa	1609.23	1751181.76	2818050341.41
Concrete	Segment 1	Block A2	Fc' 22 Mpa	1394.44	1751181.76	2441911027.67
Concrete	Segment 1	Block A3	Fc' 22 Mpa	1304.11	1751181.76	2283726734.17
Concrete	Segment 1	Block A4	Fc' 22 Mpa	1200.89	1751181.76	2102980358.02
Concrete	Segment 1	Block A5	Fc' 22 Mpa	1103.03	1751181.76	1931605636.74
Concrete	Segment 1	Block A6	Fc' 22 Mpa	903.17	1751181.76	1581621989.10
Concrete	Segment 1	Block A7.1	Fc' 22 Mpa	280.80	1751181.76	491729549.11
Concrete	Segment 1	Block A7.2	Fc' 22 Mpa	219.90	1751181.76	385085468.95
Concrete	Segment 1	Block A7.3	Fc' 22 Mpa	283.96	1751181.76	497273380.39
Concrete	Segment 1	Block A7.4	Fc' 22 Mpa	170.80	1751181.76	299107661.39
Concrete	Segment 1	Block A7.5	Fc' 22 Mpa	700.89	1751181.76	1227378607.12
Segment 1				9171.22		16060470754.06

FIGURE 1. Display result of Schedule/Quantities

(Source: BIM software)

QUANTITY TAKE-OFF CONCRETE

From the analysis process, the results obtained from BIM 5D (Quantities) in the form of concrete volume are presented in **TABLE 2**

TABLE 2. Quantity take-off concrete of spillway

Work Deskripsi	Segment	Fc'	Volume (m ³)	Cost (IDR)	Total Cost (IDR)
Concrete	Segment 1	22 MPa	9.171,22	1.751.181,76	16.060.470.754,06
Concrete	Segment 2	22 MPa	27.405,07	1.751.181,76	47.991.262.411,92
Concrete	Segment 3	22 MPa	17.585,84	1.751.181,76	30.797.138.348,53
Concrete	Segment 4	22 MPa	6.219,38	1.751.181,76	10.891.263.219,25
Total Concrete			60.382,17	1.751.181,76	105.740.134.733,76

Source: BIM software

From the analysis carried out, the total volume of Spillway is 60.382,17 m³ and total price of spillway is (IDR) 105.740.134.733,76

QUANTITY TAKE-OFF REBAR

From the analysis process, the results obtained from BIM 5D (Quantities) in the form of rebar are presented in **TABLE 3.**

TABLE 3. Quantity take off Rebar Spillway

Work Description	Segment	Weight (kg)	Cost (IDR)	Total Cost (IDR)
Rebar	Segment 1	159.158,67	14.934,00	2.376.875.632,89
Rebar	Segment 2	561.626,88	14.934,00	8.387.335.899,80
Rebar	Segment 3	493.323,89	14.934,00	7.367.163.732,35
Rebar	Segment 4	182.064,09	14.934,00	2.718.945.164,99
Total Rebar		1.401.688,25	14.934,00	20.850.320.430,03

Source: BIM software

From the analysis carried out, the total volume of rebar in spillway is 1.401.688,25 kg and total price of rebar is (IDR) 20.850.320.430,03

RECAPITULATION OF THE DIFFERENCE IN TOTAL VOLUME BETWEEN THE BIM METHOD AND THE CONVENTIONAL METHOD

From the results of the analysis carried out, and based on the volume that has been obtained from the BIM and conventional methods, the cost results from the spillway structure are obtained as shown in **TABLE 4.**

TABLE 4. Cost structure recapitulation

Method	Work Description	Cost (IDR)
BIM	Concrete	105.740.134.733,76
	Rebar	20.850.320.430,03
Total BIM result		126.590.455.163,79
conventional	Concrete	105.701.459.354,48
	Rebar	20.849.342.377,82
Total conventional result		126.550.801.732,30

Source: BIM software and conventional method

Based on the recapitulation presented in the table above, the total cost of the structure using BIM is (IDR) 126.590.455.163,79, while the conventional method is (IDR) 126.550.801.732,30. From these results, the difference in costs between using the BIM and conventional methods is (IDR) 39.653.431,49.

BIM 4D MODELLING SCHEDULE

The results of the total duration obtained using the 4D BIM method can be seen in **FIGURE 2**.

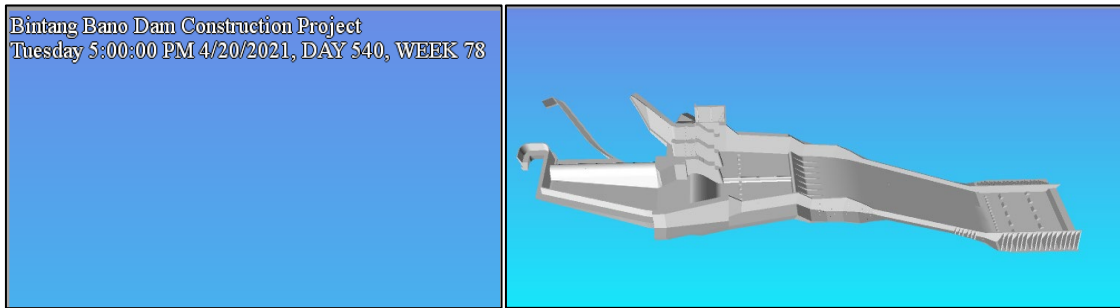

FIGURE 2. Total duration of spillway work
(Source: software BIM Schedule)

From the analysis process carried out on the software BIM schedule, the results of the total duration of the spillway structure work for 540 days.

Comparative analysis of cost and time of BIM and conventional methods

From the analysis, it was found that the cost difference based on the time span between the BIM and conventional methods. The comparison can be seen in **FIGURE 3**

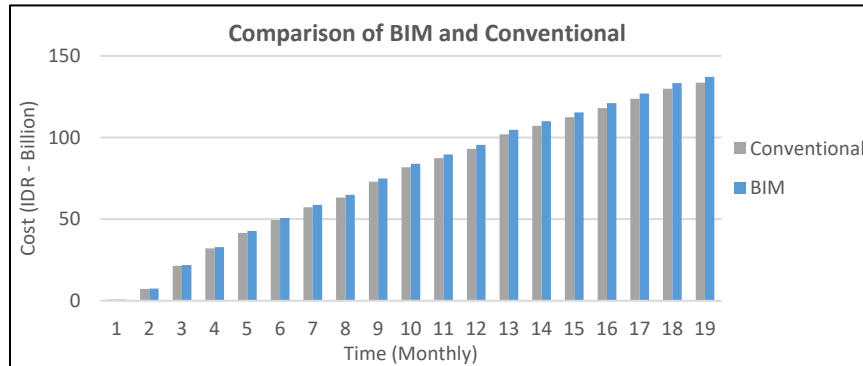

FIGURE 3. Comparison of BIM and Conventional

This study obtained the same results as previous studies, where the BIM method resulted in a higher cost than the conventional method. This is because the BIM method is more accurate for calculating complex volumes such as curves, polygons and irregular shapes.

The monthly work progress

From the analysis, it is found that the cost difference based on the time span between the BIM and conventional methods. The comparison can be seen in **FIGURE 4**.

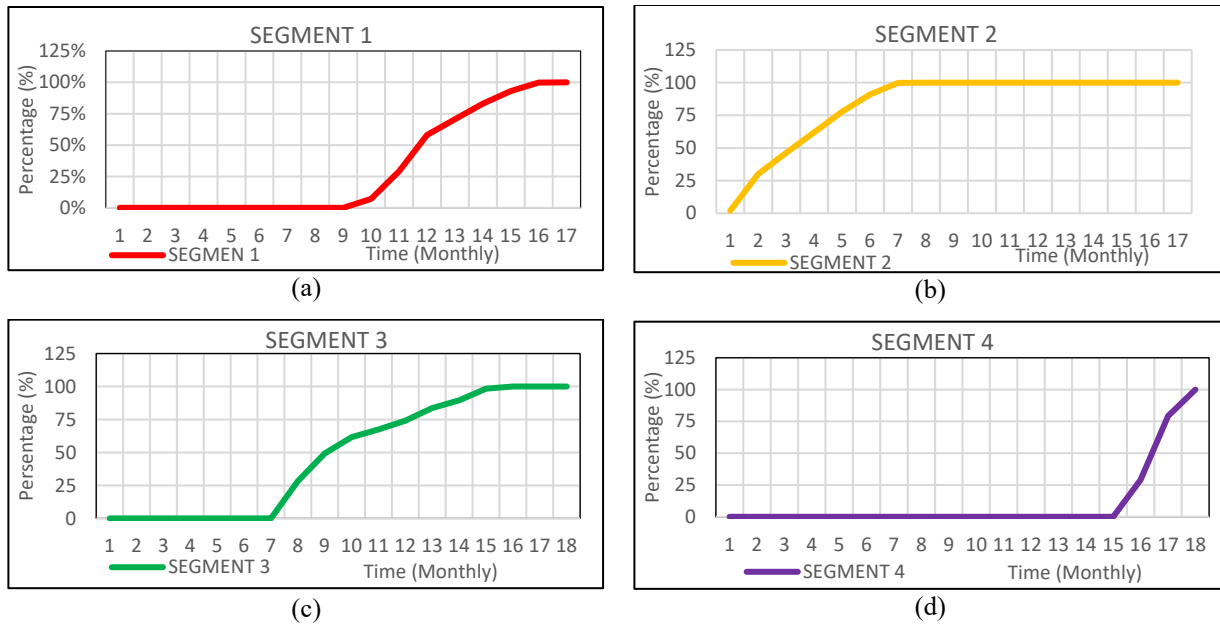

FIGURE 4. Graph of (a) The percentage of progress each month in segment 1, (b) The percentage of progress each month in segment 2, (c) The percentage of progress each month in segment 3, (d) The percentage of progress each month in segment 4
(Source: Author)

In contrast to previous studies, in this study, the authors conducted a duration analysis using the BIM method and concluded that the BIM method was able to calculate the total duration of construction and was able to monitor construction progress. In this study, the authors of BIM produce a graph of the progress of work with timeframes per month. From the chart above, the longest construction process carried out is in segment 3..

CONCLUSIONS

Based on the analysis that has been done, it can be concluded that the use of the BIM method has a higher cost than the conventional method. Whereas the conventional method results in a cost of (IDR) 126.550.801.732,30 for the spillway structure, while the BIM method results in a cost of (IDR) 126.590.455.163,79, the difference in costs is (IDR) 39.653.431,49. This is possible because the BIM method can determine the volume of structures that are asymmetrical, curved, or polygonal. And based on the analysis carried out using the 4D BIM method, the total duration of the spillway structure work is 540 days.

ACKNOWLEDGMENTS

This research did not receive any specific grant from funding agencies in the public, commercial, or not-for-profit sectors. The authors would like to thank the editor and anonymous reviewers for their comments that help improve the quality of this work

REFERENCES

- [1] H. A. Rani, "Manajemen Proyek Konstruksi," 2016.
- [2] F. Y. Wohon, R. J. M. Mandagi, and P. Pratas, "Analisa Pengaruh Percepatan Durasi Pada Biaya Proyek Menggunakan Program Microsoft Project 2013 (Studi Kasus: Pembangunan Gereja GMIM Syaloom Karombasan)," *Jurnal Sipil Statik*, vol. 3, no. 2, pp. 141-150, 2015.
- [3] A. Akhavan Tabassi, D. J. Bryde, E. Mustafa Kamal, J. Dowson, and R. Michaelides, "Challenges For Project Management In The 21st Century," *The European Proceedings of Multidisciplinary Sciences*, 2019.

- [4] P. A. Zhao and C. C. Wang, "A comparison of using traditional cost estimating software and BIM for construction cost control," in *ICCREM 2014: Smart Construction and Management in the Context of New Technology*, 2014, pp. 256-264.
- [5] C. M. Eastman, C. Eastman, P. Teicholz, R. Sacks, and K. Liston, *BIM handbook: A guide to building information modeling for owners, managers, designers, engineers and contractors*. John Wiley & Sons, 2011.
- [6] Y. C. Sari, C. A. Wahyuningrum, and N. C. Kresnanto, "Building Information Modeling (BIM) for dams-literature review and future needs," vol. 6, pp. 61-68.
- [7] M. Xie, Y. Qiu, Y. Liang, Y. Zhou, Z. Liu, and G. Zhang, "Policies, applications, barriers and future trends of building information modeling technology for building sustainability and informatization in China," *Energy Reports*, vol. 8, pp. 7107-7126, 2022.
- [8] J. Li *et al.*, "Benefits of Building Information Modelling in the Project Lifecycle: Construction Projects in Asia," *International Journal of Advanced Robotic Systems*, vol. 11, no. 8, p. 124, 2014.
- [9] A. Z. Sampaio, "Project management in office: BIM implementation," *Procedia Computer Science*, vol. 196, pp. 840-847, 2022.
- [10] P. M. Diaz, "Analysis of benefits, advantages and challenges of building information modelling in construction industry," *Journal of Advances in Civil Engineering*, vol. 2, no. 2, pp. 1-11, 2016.
- [11] P. Matejka and S. Vitasek, "Comparison of different cost estimation methods with use of building information modelling (BIM)," *Engineering for Rural Development*, vol. 17, pp. 843-849, 2018.
- [12] W. Pratoom and S. Tangwiboonpanich, "A Comparison of Rebar Quantities Obtained By Traditional vs BIM-Based Methods," *Suranaree Journal of Science and Technology*, vol. 23, no. 1, pp. 5-10, 2016.
- [13] U. Haider, U. Khan, A. Nazir, and M. Humayon, "Cost Comparison of a Building Project by Manual and BIM," *Civil Engineering Journal*, vol. 6, no. 1, pp. 34-49, 2020.