

# Bab 10

## Taufik Hasanah Syafaah -Cascade Regulator Tracking System

 Syafaah Arisnanda Irfan -Correlation factors coronary heart disease type-2 diabetes mellitus

 Teknik Elektro

 University of Muhammadiyah Malang

---

### Document Details

Submission ID

trn:oid::1:2998700681

Submission Date

Sep 5, 2024, 12:02 PM GMT+7

Download Date

Sep 5, 2024, 12:04 PM GMT+7

File Name

Taufik\_Hasanah\_Syafaah\_-Cascade\_Regulator\_Tracking\_System.pdf

File Size

1.1 MB

6 Pages

2,823 Words

15,669 Characters

# 15% Overall Similarity

The combined total of all matches, including overlapping sources, for each database.

## Filtered from the Report

- Bibliography
- Quoted Text

## Exclusions

- 4 Excluded Sources

## Match Groups

- 27 Not Cited or Quoted 15%**  
 Matches with neither in-text citation nor quotation marks
- 0 Missing Quotations 0%**  
 Matches that are still very similar to source material
- 0 Missing Citation 0%**  
 Matches that have quotation marks, but no in-text citation
- 0 Cited and Quoted 0%**  
 Matches with in-text citation present, but no quotation marks

## Top Sources

- 7% Internet sources
- 10% Publications
- 0% Submitted works (Student Papers)

## Integrity Flags

### 0 Integrity Flags for Review

No suspicious text manipulations found.

Our system's algorithms look deeply at a document for any inconsistencies that would set it apart from a normal submission. If we notice something strange, we flag it for you to review.

A Flag is not necessarily an indicator of a problem. However, we'd recommend you focus your attention there for further review.

## Match Groups

- 27 Not Cited or Quoted 15%**  
Matches with neither in-text citation nor quotation marks
- 0 Missing Quotations 0%**  
Matches that are still very similar to source material
- 0 Missing Citation 0%**  
Matches that have quotation marks, but no in-text citation
- 0 Cited and Quoted 0%**  
Matches with in-text citation present, but no quotation marks

## Top Sources

- 7% Internet sources
- 10% Publications
- 0% Submitted works (Student Papers)

---

## Top Sources

The sources with the highest number of matches within the submission. Overlapping sources will not be displayed.

- 1** **Publication**  
Lei, Ernest Yan. "Cascaded Linear Regulator with Negative Voltage Tracking Switc... 8%
- 2** **Internet**  
www.grafiati.com 7%

# Cascaded Linear Regulator Application with Positive Voltage Tracking Switching Regulator

Taufik<sup>1,a)</sup>, Brandon Nghe<sup>1)</sup>, Arief Hernadi<sup>2)</sup>, Rini Nur Hasanah<sup>3,b)</sup>, Lailis Syafaah<sup>4)</sup>

<sup>1</sup>Department of Electrical Engineering, Cal Poly State University, San Luis Obispo, USA

<sup>2</sup>Texas Instruments, Santa Clara, California, USA

<sup>3</sup>Department of Electrical Engineering, Universitas Brawijaya, Malang, Indonesia

<sup>4</sup>Department of Electrical Engineering, Universitas Muhammadiyah Malang, Indonesia

Corresponding Author: <sup>a)</sup>taufik@calpoly.edu

<sup>b)</sup>rini.hasanah@ub.ac.id

**Abstract.** This paper presents the design, simulation, and hardware implementation of a proposed method for improving efficiency of voltage regulator. Typically, voltage regulator utilized for noise-sensitive and low-power applications involves the use of a linear regulator due to its high power-supply rejection ratio properties. However, the efficiency of a linear regulator heavily depends on the difference between its input voltage and output voltage. A larger voltage difference across the linear regulator results in higher losses. Therefore, reducing the voltage difference serves as the key in increasing regulator's efficiency. This study hence proposes a pre switching regulator stage with positive voltage tracking cascaded to a linear regulator to provide an input voltage to a linear regulator which is slightly above the output of the linear regulator. The tracking capability is further required to provide the flexibility in generating different positive output voltage levels while maintaining high overall regulator's efficiency. Results from simulation and hardware implementation of the proposed system indicated the efficiency improvement of up to 23% in cases where an adjustable output voltage is deemed necessary. Load regulation performance of the proposed method also indicated better result compared to the case without the output voltage tracking method.

## INTRODUCTION

All modern electrical devices require power in order to operate, predominantly generated from AC source since as the most available and accessible device. However, most of these devices internally utilize DC power, requiring the conversion of AC to DC. The amount of DC power required by such devices range from low power consumer electronics such as mobile phones and tablets to larger power applications such as electric vehicles (EV). With this wide range of DC power requirement, it is evident that various technologies are required to properly operate the concerned devices. An EV, for example, requires much higher-level power circuits which would be different from those utilized for a low power mobile phone. Furthermore, to improve the efficiency in delivering this power, the voltage level is encouraged to be variously set during the transmission of DC power. For example, the high-power DC-DC converters for EVs operate between 36V and 48V [1][2], while the majority of mobile phones has been currently charged through 5V USB interface.

Regardless of which voltage any of these devices could operate, it is imperative to note that the circuitry to provide the power could produce a stable voltage at the desired level with significantly tight tolerance. For example, USB2.0 requires the voltage supplied by high-powered hub ports to be 4.75 V to 5.25 V [3][4]. To achieve this goal, several voltage conversion techniques were utilized, commonly acknowledged as voltage regulators.

When DC provides the source, there are mainly two methods to convert to the desired DC voltage: linear regulators and switching converters. The linear regulators are acknowledged to have very low efficiency when the input voltage is at a much higher level than in the output voltage, requiring power to be dissipated within the circuit, which is less preferred for high power applications. However, DC has advantages, which include: simple design, immune to noise, low cost, and easy to operate; hence, DC has been favored as a great choice for low power applications. The switching regulators on the other hand are acknowledged for their efficiency; and thus, they are utilized in a much broader range of applications from low to high power applications, despite suffering the major drawback of generating electrical noise both at their input and output stages. Moreover, switching regulators require more complex and larger circuitry than that of linear regulators.

Most electric power distribution systems throughout the world utilize alternating current to transmit electrical energy. The AC power systems voltage levels and frequency of transmission are various from country to country but

have been standardized to operate using 120/240 volts AC at 50/60Hz. For direct current systems, there is however no such standard [5][6][7]. Most appliances are incapable of utilizing the provided AC power by converting the AC power to an appropriate DC power to operate. Since DC is not the standard for power transmission, the operating DC voltage for many devices has thus varied. For most devices to properly operate, the input voltage levels must typically be stepped down from the supply. Based on, on the application requirements, the two ways to accomplish DC-DC conversion are conducted through switching regulators and linear regulators [8][9].

Switching regulators contain a method of DC-DC conversion that utilize switching and inductor properties to generate an output voltage [10]. Switching regulators are highly deemed efficient and capable of handling higher power levels. In addition, switching regulators are also flexible to be conducted, despite having the main downfalls in terms of design complexity and noise [11]. Switching regulators thus require several components, including: a controller, smoothing capacitors, and an inductor. The rapid switching attached in switching regulators, results in a noisy DC output and electromagnetic interference (EMI), corrupting other signals in a system [11]. Linear regulators hence serve as an alternative method of DC-DC conversion that converts a higher to a lower voltage by utilizing a series pass device that introduces the necessary voltage drop despite dissipating power as heat [12][13]. Linear regulators provide a simple and cheap solution for low power DC-DC conversion as means of a fast transient response, allowing immediate response to changes in input or load. Unlike switching regulators, there is no switching noise in linear regulators, enabling the generation of a low-noise output voltage. The major disadvantages of linear regulators lie in factors such as lack of flexibility, efficiency, and power capability. Linear regulators are also efficient when the input voltage is close to the output voltage. In cases where there is a large voltage difference between the two, the voltage difference translates to the dissipated power as heat, resulting in poor efficiency and thermals.

## DESIGN

Figure 1 indicates the block diagram of the proposed method, generating an input voltage and an output voltage that is dependent on the configuration of the board. This circuit is designed to maximize efficiency. The switching regulator transmits the input voltage and the feedback to generate a lower output voltage which fed into the linear regulator. The linear regulator is used to remove switching noise and generate a clean output voltage. The feedback stage comprising the tracking pre-regulator block is responsible to create a feedback voltage for the switching regulator based on the switching regulator's output and the linear regulator's output.

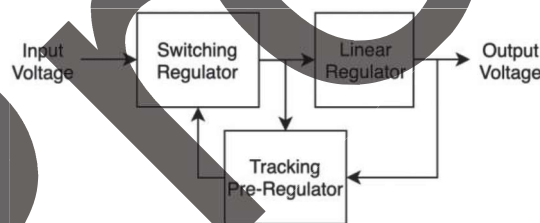

FIGURE 1. Block diagram of the proposed system

The main goal of the project is to design and test a method of improving the switching regulator and linear regulator cascade topology. The focus is to use a circuit minimizing the voltage difference between the linear regulator's input and output voltage to reduce the power loss. Efficiency is measured in the final system. Table 1 summarizes the technical requirements for the DC-DC conversion system for the proposed system.

Hence, selecting an appropriate buck controller for the switching regulator is essential. The LT3971A is an adjustable frequency monolithic buck switching regulator having a wide input voltage range of 4.3V to 38V, and an adjustable output voltage from 1.19V to 30V, additionally capable of outputting a maximum current of 1.3A.

To size the inductor in the buck converter, a common practice is to utilize a percent peak-to-peak inductor current ripple  $\Delta i_L$  between 30% and 40% of the maximum load current [10]. In this case, for the maximum output current of 500mA, the inductor current ripple is approximately 200mA. Furthermore, the output voltage of buck regulators is slightly higher than the linear regulator's output voltage by about 1.9V due to the inclusion of the pre-regulator tracking. The maximum critical inductance is found when the linear regulator's output voltage is 5V. The assumption of an efficiency of 90% generates the critical inductance as Equation 1.

$$L_C = (V_{in} - V_{out}) \frac{D}{\Delta i_L f} \quad (1)$$

$$L_c = (15V - (5V + 1.9V)) \frac{5V + 1.9V}{15V * 0.9} = 51.75\mu H$$

Ideally, an inductor of 56μH would be selected. However, due to limitations, the only available value for prototyping was a 47μH. This lower inductance resulted in higher inductor of current ripple and higher RMS losses.

**TABLE 1.** Technical Requirements of Tracking Regulator for Switching-LDO System

Specification	Value	Justification
Input voltage	15VDC	This system will use DC input power. This value was chosen as it is a slightly higher voltage than 12 VDC, a common voltage for a power supply.
Efficiency	Greater than 85%	This system will be designed for high efficiency. With the proposed feedback regulation for the linear regulator, the losses are expected to be minimized.
Average Output Voltage	1.5, 3.3, 5, 9, 12VDC	This system will use a first stage buck switching regulator, so we will only have values less than our input. These values are common low DC voltage levels.
Maximum Average Output Current	500 mA	The output current is limited due to the use of a linear regulator. The total system is intended for low-power applications.

The input capacitor of the converter allows potential disruptions in the power supply voltage. The maximum capacitance is achieved when the linear regulator’s output voltage reaches 5V. Furthermore, the capacitance size has to be selected using Equation 2 based on a reasonable peak to input voltage ripple hindering large capacitance thus increasing cost and converter size as well as causing bigger losses due to large input voltage ripple. This study utilized a commonly utilized peak to peak voltage ripple of 5% [10].

$$C_{in} \geq \frac{D(1 - D)I_o}{\Delta V_{in} f_s} = \frac{5V + 1.9V}{15V * 0.9} \left(1 - \frac{5V + 1.9V}{15V * 0.9}\right) (500mA) = 41.6\mu F$$

To achieve this input capacitance, a 22μF electrolytic capacitor is connected in parallel with a 22μF ceramic capacitor to allow for lower equivalent series resistance of the capacitors; thus, reducing losses.

The output capacitance of the converter depends on the desired peak to peak output voltage ripple, because the output will serve as the input to a linear regulator having a high-Power Supply Ripple Rejection ratio (PSRR), causing the output voltage ripple of the switching regulator to be more lenient. The output capacitance is obtained by calculated equation 3. As for the input capacitance, the ripple is selected to achieve 5% of the output voltage. The minimum duty cycle is achieved when the output of the linear regular is set 1.5V.

$$C_{out} \geq \frac{(1 - D_{min})}{8L f_s^2 \left(\frac{\Delta V_o}{V_o}\right)} = \frac{\left(1 - \frac{1.5V + 1.9V}{15V * 0.9}\right)}{8(47\mu H)(400kHz)^2(0.05)} = 26.2\mu F$$

When selecting the linear regulator, it is thus imperative to navigate one, capable of handling the output voltage from the buck regulator, with adjustable output voltage and output current as illustrated in Table 1. The LT1963A is a regulator that allows input voltage up to 20V, an adjustable output voltage from 1.21V to 20V, delivering a maximum output current of 1.5A; thus, fulfilling the design needs of this project.

## SIMULATION AND HARDWARE RESULTS

The illustrated circuit in Figure 2 is simulated in LTSpice for output voltages of 1.5V, 3.3V, 5V, 9V, and 12V. The plots in Figure 3 and Figure 4 indicate the transient response of the buck output voltage and linear regulator output voltage. The simulations function as expected for all cases, as the regulator achieves steady state in 2ms after startup. In addition, the output voltage of the switching regulator follows the linear regulator output voltage, indicating the tracking circuit which maintains a linear regulator voltage difference of 1.87V.

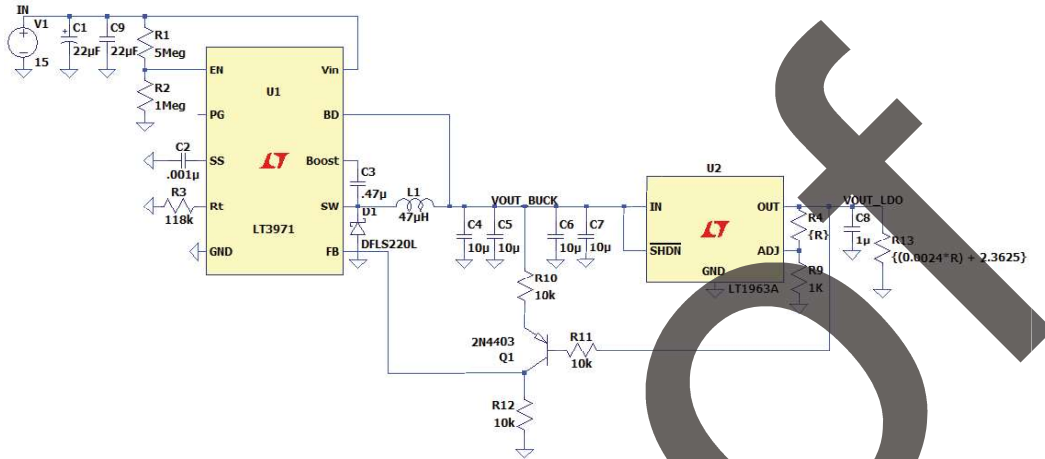

FIGURE 2. LTSpice schematic of the proposed system

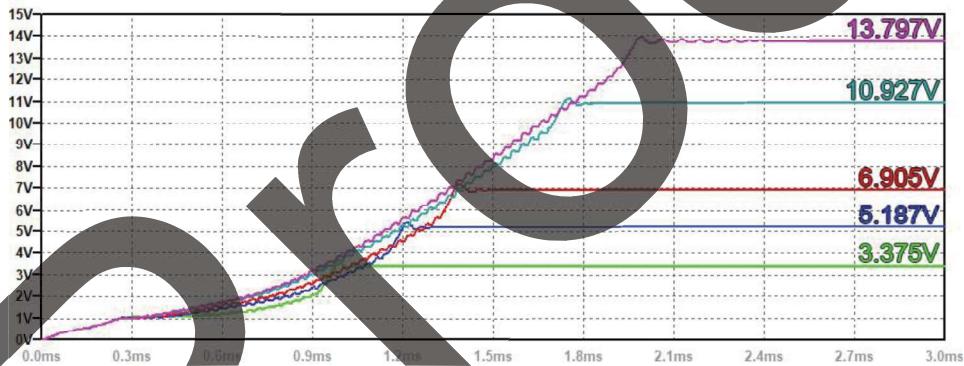

FIGURE 3. Transient of the switching regulator output voltage

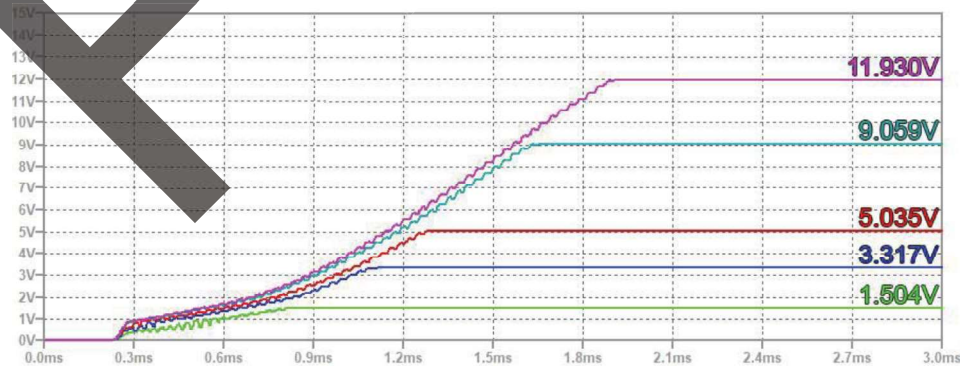

FIGURE 4. Transient of linear regulator output voltage

For comparison, the circuit is entirely sustained except the feedback network is removed. The buck controller's resistive divider is set to generate a buck output voltage of 12.5V to be slightly higher than the linear regulators highest output voltage of 12V. For both circuits, the efficiency of the entire regulator and power loss from the linear regulator



is observed and illustrated in Figure 5 for output voltages of 1.5V, 3.3V, 5V, 9V, and 12V with an output current of 500mA.

The break-even point for both efficiency and linear regulator losses of both boards is at approximately 10.6V, as the converter without tracking has a switching converter output of about 12.5V. The converter with pre-tracking holds the voltage difference, constant for all output voltages; whereas the converter with normal feedback will have a larger voltage difference when the output is lower than 10.6V. This linear regulator voltage difference is directly related to the efficiency and power loss of the converter. Without tracking, linear regulator losses are higher in the lower output voltage. Therefore, in cases where multiple output voltages are not necessary, the tracking regulator would be ineffective at reducing losses.

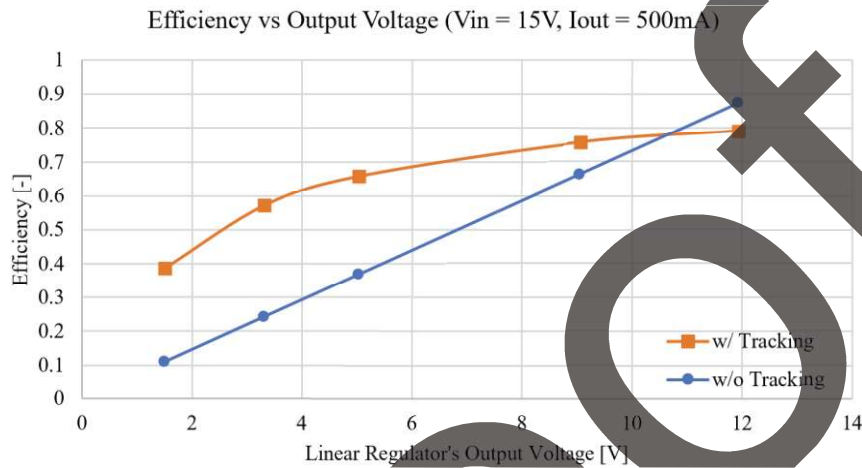

FIGURE 5. Simulation Results: Efficiency comparison of switching + linear regulator with and without pre-tracking regulator

The proposed system and the circuit without the tracking pre-regulator were constructed. Figure 6 indicates the assembled board for the proposed system. Efficiency test and measurements were then conducted to compare the performance of the proposed system without the tracking pre-regulator. Figure 7 illustrates the efficiency plots of both converters.

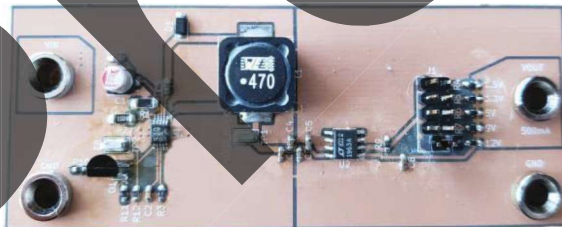

FIGURE 6. The final proposed converter board with pre-tracking regulator

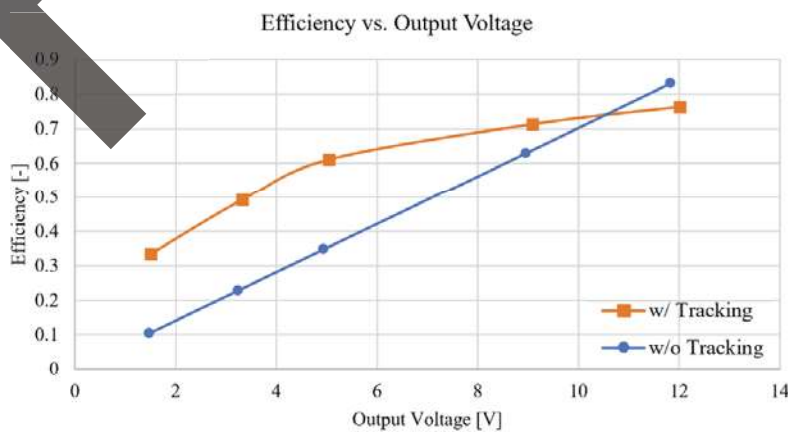

FIGURE 7. Hardware Results: Efficiency comparison of switching + linear regulator with and without pre-tracking



Upon referring to the simulation data, the regulator with pre-tracking yields more efficient results of the two boards when the output voltage is less than 10.5V and is less efficient when the output is greater than 10.5V. The linear regulator losses are almost equal at all voltages when tracking is implemented. Without the tracking, the linear regulator losses are inversely proportional to output voltage. Moreover, efficiency and linear regulator losses are measured while sweeping output current for output voltages of 1.5V, 5V, and 12V.

## CONCLUSIONS

The proposed converter with the pre-tracking circuit indicated a profound result in reducing the power loss of the linear regulator in a variable output cascaded of DC-DC converter by maintaining a voltage difference across the linear regulator when changing the output voltage. Hardware testing and results were relevant with the simulation data. Variations in data could attribute to non-idealities of components and board layout. Furthermore, such differences emerged as a result of parasitic capacitances and inductances, electromagnetic interference, and thermal behavior.

The hardware results indicated areas for improvement. A more efficient system was feasible to be achieved by increasing the collector resistor or decreasing the emitter resistor of the pre-tracking regulator after start-up stage. Such resistors were capable of altering to reduce the difference across the linear regulator, upon undergoing a steady-state operation.

The proposed pre-tracking regulator demonstrated its ability to have the switching converter's output in accordance with the linear regulator's output to improve the overall regulator's efficiency. Efficiency of the converter with the pre-tracking regulator ranged from 33% to 76% compared to a converter with normal feedback ranging from 10% to 83%. This result is deemed most effective when applying a low-noise DC-DC conversion to various output voltages. In situations where only a single output voltage with low-noise is required, it is thus more effective to design a cascaded converter with normal feedback, where the switching regulator is set to have an output voltage, significantly close to the linear regulator's output.

## ACKNOWLEDGMENTS

The researchers of this study would like to express their gratitude for the Texas Instruments upon providing and supporting the project presented in this paper.

## REFERENCES

1. A. Khajezadeh and A. M. Javadi, "Study and Simulation of a DC/DC Converter in Hybrid Electric Vehicle," *International Journal of Scientific & Engineering Research*, **5**, 828–832 (2014),
2. D. Magdefrau, T. Taufik, M. Poshtan, and M. Muscarella, "Analysis and review of DC microgrid implementations," in *2016 International Seminar on Application for Technology of Information and Communication (ISemantic)*, 241–246 (2016).
3. H.-P. Compaq and L. Intel, "Universal serial bus specification revision 2.0," (2000).
4. R. N. Hasanah, T. Starr, E. Gazali, and T. Taufik, "DC-DC Converter for USB-C Power Adapter in Residential DC Electricity," in *2019 IEEE Conference on Energy Conversion (CENCON)*, 207–212 (2019).
5. Panasonic, "Find the Right Battery for Your Application."
6. Intel, "Power Supply - Design Guide for Desktop Platform Form Factors," *Design Guide*, 104 (2018).
7. Yuasa, "Battery Application & Specification Guide 2015," (2015).
8. J. J. Crowfoot, "Design and modeling of the Cal Poly DC house power distribution system," (2011).
9. W. Kester and B. Erisman, "Section 3 Switching Regulators," *Analog Devices Technical Library on Power Management*, **3**, (2006),
10. D. Taufik, "Introduction to Power Electronics 7 th Revision," *California, San Luis Obispo*, (2009).
11. ONSEMI, "Effects of High Switching Frequency on Buck Regulators," *Enabling Energy Efficient Solutions*, 1–24 (2009),
12. R. S., "Basics of Linear Regulators," *Rohm Semiconductor*, **EAY17**, 1–6 (2015),
13. T. The, *Understanding the Importance of Low-Noise Linear Power Supplies*.